

Eddystone Radio

830/1, 2, 3.

INSTALLATION NOTES
OPERATING INSTRUCTIONS
AND
SERVICE DATA

Eddystone User Group



EDDYSTONE MODEL 830/1/2/3
HF/MF COMMUNICATIONS RECEIVER

The EDDYSTONE Model 830 is a general purpose HF/MF communications receiver covering the frequency band 300 kc/s to 30 Mc/s in nine ranges. Double conversion is used on the frequencies above 1.5 Mc/s and the 1st IF is variable to provide an incremental tuning facility with a coverage of ± 100 kc/s. Both Local Oscillators can be crystal controlled for high stability applications on frequencies above 1.5 Mc/s.

Provision is made for reception of CW, AM and SSB, the IF bandwidth is continuously variable and a separate detector is employed for CW/SSB reception. A crystal filter is provided for selective CW reception and when taking SSB the BFO pitch adjustor serves as a fine tuning control with an approximate swing of ± 100 c/s.

Audio outputs are available for connection to an external loudspeaker, telephones and remote lines. Other facilities include a low impedance IF output (100 kc/s), an efficient noise limiter, a carrier level meter and a built-in crystal calibrator. The AGC line is brought out to a socket at the rear to permit interconnection of receivers in diversity, while other terminations on the same socket allow the receiver to be muted when an associated transmitter is in operation.

The power supply arrangement is such that the receiver can be operated direct from any standard AC mains supply or alternatively from any external source capable of giving the appropriate HT and LT voltages. Ancillary supplies are available when operating from the mains.

The Model 830 can be supplied either as a standard unit for surface mounted installations or as a rack mounting unit (830/RM) for use in a 19" rack. Either version can be fitted with shock-absorbent mountings for use in mobile installations.

LIST OF CONTENTS

<u>Section</u>	<u>Page</u>
Technical Data	2
Circuit Description	5
Constructional Details	11
Installation	13
Operation	17
Maintenance	26
 <u>Appendices</u>	
Appendix 'A' Models 830/1, 830/2 and 830/3	34
Appendix 'B' Table of Voltage Values	35
Appendix 'C' List of Component Values, Tolerances and Ratings	36
Appendix 'D' Spares	42
 <u>Illustrations.</u>	
Fig. 1. Block Schematic Diagram	45
Fig. 2. Plan View of Receiver	46
Fig. 3. Underside View of Receiver	47
Fig. 4. Circuit Diagram	Rear cover

The Company reserve the right to vary the information contained in this publication

Sole Manufacturers:- STRATTON & CO., LTD., ALVECHURCH ROAD, BIRMINGHAM 31, ENGLAND.

TECHNICAL DATA

GENERAL

Frequency Coverage.

300 kc/s to 30 Mc/s in nine ranges.

Range 1	. .	18.0 - 30.0 Mc/s.	Range 6	. .	1.5 - 2.5 Mc/s.
Range 2	. .	11.0 - 18.0 Mc/s.	Range 7	. .	860 - 1500 kc/s.
Range 3	. .	6.7 - 11.0 Mc/s.	Range 8	. .	480 - 860 kc/s.
Range 4	. .	4.0 - 6.7 Mc/s.	Range 9	. .	300 - 520 kc/s.
Range 5	. .	2.5 - 4.0 Mc/s.			

Intermediate Frequencies.

1st IF	. .	Nominally 1350 kc/s but variable over the range 1250-1450 kc/s to provide the incremental tuning facility on Ranges 1-6. The 2nd IF becomes the 1st and only IF on Ranges 7, 8 and 9.
2nd IF	. .	100 kc/s with crystal filter and variable selectivity. The BFO is controlled by a capacity diode and provides a 'fine' tuning facility on SSB (± 100 c/s). Pitch adjustment on CW is approximately ± 3 kc/s.

Valve Complement.

Ref	Type	Circuit Function
V1	6ES8 or ECC189 (CV5331)	RF Amplifier (cascode).
V2	6AK5 or EF95 (CV850)	1st Mixer.
V3	6C4 or EC90 (CV133)	2nd Local Oscillator (VFO and CRYSTAL).
V4	6AK5 or EF95 (CV850)	2nd Mixer.
V5	6BA6 or EF93 (CV454)	1st 100 kc/s IF Amplifier.
V6	6BA6 or EF93 (CV454)	2nd 100 kc/s IF Amplifier.
V7	6AL5 or EB91 (CV140)	Noise Limiter.
V8	6AU6 or EF94 (CV2524)	Cathode Follower (IF OUTPUT).
V9	6AT6 or EBC90 (CV452)	AM Detector/AGC Rectifier/Audio Amplifier.
V10	6AQ5 or EL90 (CV1862)	Audio Output.
V11	6AU6 or EF94 (CV2524)	Crystal Calibrator.
V12	6U8 or ECF82 (CV5065)	1st Local Oscillator (VFO and CRYSTAL).
V13	6BE6 or EK90 (CV453)	CW/SSB Detector.
V14	0A2 or 150C4 (CV1832)	HT Stabiliser (1).
V15	0A2 or 150C4 (CV1832)	HT Stabiliser (2).
D1	100SC2 -	Variable Capacity Diode (BFO).
D2/5	*DDO06 -	HT Rectifier.

Input and Output Impedances.

Aerial Input	. .	75 Ω (nominal) unbalanced.
IF Output	. .	250 Ω (nominal) unbalanced. Suitable for terminating impedances in the range 75-300 Ω .
Audio Outputs	. .	Loudspeaker : 2.5/3 Ω . Lines : 600 Ω (balanced or unbalanced). Telephones : Nominally 2000 Ω but suitable for a wide range of impedances.

*2 x DD058 may be fitted in lieu.

Power Supplies.

Mains Operation 100/125V and 200/250V AC (40-60 c/s).
Consumption : 85 volt-amperes.

External Power Supplies External HT and LT supplies required to operate the receiver in the absence of AC mains are as follows:-
HT : 250V @ 160mA. LT : 6.3V @ 4.8A (approx.).

Accessory Supplies The following supplies are available for powering external units when the receiver is mains operated:-
HT . . . 250V @ 15mA (unsmoothed).
LT . . . 6.3V @ 1.2A (earthed centre-tap).

Fusing 830 and 830/1 . . . Both sides of the mains input are fused at 2A.
..... 830/2 . . . The live side of the mains input is protected by a 1.5A thermal storage delay fuse.

Fuses are standard cartridge types, these being 20mm long in the case of the 830 and 830/1, 1½" long in the case of the 830/2.

External supplies should be switched and fused at their source.

TYPICAL PERFORMANCE FIGURES

Sensitivity.

With an IF bandwidth of 3 kc/s, the sensitivity is better than 3µV for a 15dB signal to noise ratio at all frequencies throughout the range.

IF Selectivity.

The overall bandwidth at 6dB down is continuously variable within the limits 1.3 kc/s to 6 kc/s and is narrowed to 50 c/s when using the 100 kc/s crystal filter.

Markings on the selectivity control indicate the appropriate bandwidths for 'AM' 'SSB' and 'CW'. The extreme 'CW' position is marked 'N' (narrow) and moving the control to this setting introduces the pre-phased crystal filter. Click stops are provided for positive selection of the 'SSB' and 1.3 kc/s 'CW' positions.

Typical overall bandwidths are given in the Table below.

Position	-6dB	-50dB
CRYSTAL (N)	50 c/s	2 kc/s
CW	1.3 kc/s	5 kc/s
SSB	3 kc/s	8 kc/s
AM	6 kc/s	12 kc/s

IF Breakthrough. (1st IF)

Greater than 70dB down except at 1.5 Mc/s on Range 6 where a figure of -60dB is obtained.

Any given breakthrough at the 1st IF (1350 kc/s ± 100 kc/s) can be eliminated by de-tuning the incremental control and re-setting the main tuning to re-tune the wanted signal.

IF Breakthrough. (2nd IF)

Greater than 85dB down at all frequencies except Range 9 (300-520 kc/s) where a figure of greater than -60dB obtains.

Image Rejection.

On Ranges 7, 8 and 9 (300 kc/s - 1.5 Mc/s) where the image is 200 kc/s removed from the signal frequency, a rejection of at least 50dB is obtained.

At frequencies in the range 1.5-10 Mc/s the image rejection is greater than 70dB and at 30 Mc/s the figure does not drop below 50dB.

As with breakthrough at the 1st IF, any given image occurring in the band 1.5-30 Mc/s can be eliminated by adjustment of the incremental control.

Calibration and Re-setting Accuracy.

The main scale accuracy on all ranges without use of the calibrator and with the cursor adjuster at mid-travel is within 0.5%, provided that on Ranges 1-6 (1.5-30 Mc/s) the 1st IF is set to the centre of its coverage (1350 kc/s).

When the main scales are standardised against the built-in calibrator, frequencies can be set to within one kilocycle by adjustment of the incremental control.

The incremental facility is not available on Ranges 7, 8 or 9 (300-1500 kc/s).

Frequency Stability.

After a 10 minute warm-up period, drift with free running oscillator is approximately 25 kc/s in the first hour at 28 Mc/s. After a further 30 minutes operation, drift at any frequency will not exceed 4 parts in 10^4 .

With crystal control of the 1st Local Oscillator, drift during the first 30 minutes of operation does not exceed 2 kc/s. After this time the drift will be considerably less than one kilocycle in any one hour period.

AGC Characteristic.

The audio output level does not change by more than 9dB when the carrier level is increased 90dB above $3\mu\text{V}$. (Taken at 8 Mc/s with an IF bandwidth of 3 kc/s).

The normal AGC discharge time constant (0.15 sec.) becomes 10 seconds when the Mode switch is moved to the 'SSB' positions. The AGC delay is also reduced under this condition of operation.

AGC is available for diversity working. (Socket at rear of receiver).

Audio Output and Response.

The Audio Output Stage will deliver a maximum output of 2.5 watts at either the 2.5 Ω or 600 Ω outputs when these are used independently.

The audio response is level within 6dB over the range 200 c/s to 6 kc/s.

Distortion.

5% at 1 watt in 2.5 Ω at 1000 c/s.

Hum Level.

Greater than 50dB down on 2.5 watts.

IF Output.

An input of $3\mu\text{V}$ at the aerial socket will produce an output of at least 50mV across 75 Ω (100 kc/s).

CIRCUIT DESCRIPTION

THE RF SECTION

This portion of the receiver comprises V1 (6ES8/ECC189), V2 (6AK5/EF95) and V12 (6U8/ECF82). The first stage is a high gain RF Amplifier which uses a low noise double-triode in a series cascode circuit. This arrangement is used in preference to the more conventional pentode amplifier because of its superior performance with respect to blocking, cross modulation etc.

The input tuning arrangements on the six HF ranges (i.e. above 1.5 Mc/s), are of the bandpass type with double tuned circuits. Common inductance coupling is used between each pair of coils and this takes the form of the earth return wiring inductance on the three highest ranges. Small ferrite beads are included in the wiring to give suitable inductance values for Ranges 2 and 3. On Ranges 4, 5 and 6 coupling coils are used and these are wound on the same former as that used for the secondary coil of each pair. On the three lowest frequency ranges (7, 8 and 9 : 300-1500 kc/s) a single tuned circuit is used in place of the bandpass arrangement.

Individual self-locking air-spaced trimming capacitors are used for the tuned windings, all of which have iron dust cores for precise adjustment of inductance value. Absorption effects are overcome by arranging the switching to short-circuit all coils except those actually in use.

Manual RF gain control is effected in the cathode circuit of the first triode. The variable resistor RV1 provides this facility and its range of adjustment is increased considerably by a bleed current derived from the 47,000 Ω resistor R5. Under normal operating conditions RV1 is returned direct to ground via S2a (normally closed) and the short circuit across SKT3/1 and SKT3/4.

S2a forms part of the Calibrator switch and its function is to introduce R4 in series with the cathode return of the first triode portion of V1 when the switch is in the 'Calibrate' position. The voltage developed across R4 and (RV1), which with R5 form a potential divider across the HT line is sufficient to bias-off the RF Amplifier valve and so limit interference from outside signals while a calibration check is being carried out.

The two socket connections SKT3/1 and SKT3/4 are for termination of a switch or relay contact forming part of an external send/receive changeover circuit. The switch or relay should be arranged to close the SKT3 circuit for normal operation on 'receive' and open to introduce R77 on 'transmit'. In the latter condition, the voltage developed across R77 desensitises both the RF Amplifier and the 1st 100 kc/s IF Stage (the cathode of which is also returned to SKT3) so that the receiver is effectively muted while a transmission is in progress. CE2 reduces clicks during keying. If a variable level of muting is required, this can be achieved by the simple expedient of connecting a 50,000 Ω variable resistor across the SKT3 connections (i.e. in parallel with R77). The variable resistor will function as a combined RF/IF Gain control and allow the sensitivity to be set to suit the proximity and power output of the local transmitter.

The stopper R2 (12 Ω) in the grid of the first triode section prevents any tendency towards VHF parasitic oscillations which would affect the operation of the amplifier at its normal working frequencies. AGC is applied to the first grid via R1a (0.27M Ω) and the grid of the second triode derives its bias from the potential divider R7/R8. C34 and C34a (low inductance types) ground the grid of the second triode at signal frequencies and so maintain stability in the cascode stage.

Various forms of coupling are employed between the RF Amplifier and the 1st Mixer Stage V2. On Ranges 1-5 and Ranges 7 & 8, conventional primary windings are used with additional top capacity coupling in the form of C36-C39. Range 6 utilises a straight-forward resistance-capacity method while on Range 9 a variation of this system is used in which C57 acts as a common coupling impedance. Self-locking air-spaced trimmers and iron dust cores are used for the secondary windings and the shorting arrangements to prevent absorption effects are the same as on the aerial input circuits.

Full AGC is applied to V2 through R13 (0.47M Ω) and the oscillator injection is to the cathode at low impedance via C164. A coaxial lead is taken from the anode of the Mixer to one section of the Range switch (S1f) which selects the appropriate IF circuit for either single or double conversion operation. Double conversion is used on Ranges 1-6 (1.5-30 Mc/s) and in this case the anode is taken to the tunable IF transformer L34/L35. On frequencies below 1.5 Mc/s (Ranges 7, 8 and 9), the switching bypasses the second stage of frequency conversion and the anode feeds directly to the 1st 100 kc/s IF transformer T1.

The 1st Local Oscillator circuit uses a triode-pentode and is arranged as a combined VFO and Crystal Oscillator. The pentode portion (V12A) functions as the VFO with the screen grid working as an anode. Output is taken from the anode proper at low impedance and this arrangement besides simplifying the injection feeds from V12A and V12B, also contributes a high degree of isolation for the variable oscillator and so eliminates any possible pulling of the oscillator frequency. Both the variable oscillator and V12B operate at low output to minimize oscillator radiation.

Temperature compensation is applied to the variable oscillator which is a conventional tuned-grid type and tracks on the high side of the signal on all ranges. The HT supply is derived from the stabilised line (HT3) and is applied via one section of S6a when this is placed in the 'Manual' position. High quality self-locking air-spaced trimmers are used on all ranges and the padding capacitors are high stability close tolerance types.

The triode portion of V12 is a Colpitt's type oscillator in which the crystal operates at its fundamental frequency. Output is taken from the cathode at low impedance through C165 to join the VFO output source at the anode of V12A. This arrangement avoids the necessity for switching the oscillator outputs and the changeover from 'Manual' to 'Crystal' working is thus restricted to a single switch (S6a) which applies HT3 to the appropriate stage.

Multiples of the crystal frequency are generated in the 1st Mixer Stage and this allows the 2nd or 3rd harmonics to be used for mixing. The injection frequency can be chosen either above or below the signal so that a single crystal will provide a total of six different 1st Oscillator frequencies. Eight crystals can be in position at any one time and these are brought into circuit by the Crystal Selector Switch S6b which is arranged to short-circuit all crystals except the one actually in use. The incremental tuning facility which will be described later makes for greater flexibility in the choice of crystal frequency because it allows simple correction at the 1st IF for errors of up to ± 100 kc/s in the nominal crystal or harmonic frequency. Reference should be made to the Section dealing with 'Operation' on Page 22 for more detailed information on the calculation of crystal frequencies.

THE TUNABLE 1ST IF

When Ranges 1-6 are selected (receiver operating with double conversion), the anode of the 1st Mixer Stage is connected by S1f to the primary winding of the tunable IF transformer L34/L35. At the same time, the 2nd Mixer (V4 : 6AK5/EF95) and its associated Local Oscillator are brought into operation by a further section of the Range switch (S1g) which completes the HT3 supply circuit. On Ranges 7, 8 and 9, HT is removed and the anode of the 1st Mixer is routed by S1f direct to the 100 kc/s IF.

L34 and L35 are tuned over the range 1250-1450 kc/s by two sections of the three-gang incremental tuning capacitor, the third section of which tunes the 2nd Local Oscillator V3. This stage employs a general purpose triode (6C4/EC90) in a temperature compensated tuned-anode circuit and tracks on the low side of the 1st IF, covering the band 1150-1350 kc/s to give a 2nd IF of 100 kc/s.

As an alternative to the incremental facility, V3 can be locked at any frequency in the range 1150-1350 kc/s by removing link 'X' and fitting a suitable crystal in the holder which is provided for this purpose. The crystal operates in its series mode and the frequency of oscillation can be 'pulled' slightly by adjustment of the incremental tuning control.

Injection to the 2nd Mixer is at low impedance to the cathode and is derived from a small coupling winding on the oscillator coil L36. The level of injection is low to ensure minimum oscillator leakage and so reduce the level of spurious signals generated within the receiver. All circuitry associated with the 2nd conversion stages is completely screened and as a further measure all supply leads are taken into the unit via feed-through capacitors. IF input and output leads are run in coaxial cable.

The three main advantages of the incremental tuning facility are (1) constant calibrated bandspread is available at all frequencies in the range 1.5-30 Mc/s so that frequencies can be read to a high degree of accuracy; (2) a tuning rate comparable with that obtained with the main tuning control on the lower frequencies is available on the high frequency bands, and (3) the choice of crystal for spot frequency control of the 1st Local Oscillator can be anywhere in the range $(fs \pm 1250 \text{ kc/s})$ to $(fs \pm 1450 \text{ kc/s})$. Thus fewer crystals are required for control of the 1st Local Oscillator to give coverage of all frequencies in the range 1.5-30 Mc/s.

An important point which must be borne in mind when using the tunable 1st IF in conjunction with crystal control of the 1st Local Oscillator is that the incremental scale is calibrated to indicate higher and lower signal frequencies on the assumption that the 1st Oscillator frequency is higher than the signal frequency. This is always the case when using 'Manual' control but when the 1st Oscillator is crystal controlled the injection frequency can be chosen on the lower side of the signal with the result that the incremental calibration is reversed.

The reason for this can be clarified by taking a typical example. Assume that the receiver is to be crystal controlled to cover the 200 kc/s band 6600-6800 kc/s. Injection can be above or below this range and the appropriate frequencies can be determined by applying the following formula:

$$\text{INJECTION FREQUENCY} = \text{BAND CENTRE FREQUENCY} \pm \text{NOMINAL 1ST IF}$$

The 'band centre frequency' in this example is 6700 kc/s and the nominal 1st IF 1350 kc/s so that applying the formula for both cases will give the following results:

$$6700 + 1350 = \underline{8050 \text{ kc/s}} \quad \text{and} \quad 6700 - 1350 = \underline{5350 \text{ kc/s}}$$

Now consider the effect of detuning the 1st IF to its lowest frequency (1250 kc/s). The effective signal frequency at this setting of the incremental control can be determined by calculating as follows:

$$\text{SIGNAL FREQUENCY} = \text{1ST OSCILLATOR FREQUENCY} - \text{1ST IF} \quad (\text{if 1st Osc. is 'high'})$$

$$\text{or } \text{SIGNAL FREQUENCY} = \text{1ST OSCILLATOR FREQUENCY} + \text{1ST IF} \quad (\text{if 1st Osc. is 'low'})$$

Continuing the example above will give the following frequencies:

$$8050 - 1250 = \underline{6800 \text{ kc/s}} \quad \text{and} \quad 5350 + 1250 = \underline{6600 \text{ kc/s}}$$

It is immediately obvious that since the effective signal frequency is the same in both cases when the 1st IF is at 1350 kc/s, a reversal must occur when the 1st Oscillator is placed on the LF side of the signal. The range 6600-6800 kc/s is covered with either crystal but when using the lower channel allowance must be made for the reversal when reading frequencies from the incremental scale.

This subject is dealt with in greater detail in the Section on 'Operation' but it is worth noting at this stage that the basic rule applicable to the tunable IF assuming that the 1st Oscillator is 'high' is that a decrease in IF is required to produce an

increase in signal frequency. This factor has been taken into account in presenting the incremental calibration which is strictly conventional in that a red reading is used to indicate that the receiver is tuned to a frequency higher than that indicated by the main tuning scale, while calibration in black denotes a lower frequency.

The misalignment of the RF and Mixer signal circuits which results when the 1st IF is detuned from its nominal frequency can be corrected by the 'Peak RF' control. This takes the form of a three-gang variable capacitor of relatively low capacity which is wired in parallel with the signal frequency sections of the main tuning gang. The receiver is aligned with the 'Peak RF' capacitors at half-capacity so that both positive and negative correction is possible in subsequent use.

THE 2ND IF AND AUDIO SECTION

Output from the appropriate Mixer is fed via T1 to the two-stage 100 kc/s IF Amplifier which comprises V5 and V6 (6BA6/EF93). Both stages operate with AGC which is shunt fed via R28/R38. The first stage can be controlled manually by means of the IF Gain control RV2 which, like the RF Gain, has its range of adjustment increased by a bleed current derived from the main HF line (via R30) and is also returned via SKT3-1/4 to further reduce the overall gain when an associated transmitter is in operation.

Variable selectivity is achieved at the 2nd IF by physical movement of the primary coils of the transformers T1, T3 and T4. The selectivity is continuously variable by a panel control which has a positive stop to ensure correct selection of the appropriate bandwidth for 'SSB' reception.

At the extreme 'CW' position of the selectivity control a further click-stop is provided and a small arm attached to the mechanical drive actuates a switch to introduce the 100 kc/s crystal filter. This is pre-phased by the trimmer C88 to provide a symmetrical response with a 6dB bandwidth of the order 50 c/s.

The second 100 kc/s IF Amplifier provides a controlling voltage to operate the built-in carrier level meter. This voltage is developed at the junction of the two screen resistors R35/R36 and the meter is connected between this point and the slider of the potentiometer RV3. This is a pre-set control and is adjusted initially under 'no-signal' conditions, (with the RF and IF Gains at maximum and the AGC 'ON') to position the meter needle coincident with the zero mark at the left-hand side of the meter scale, (i.e. the slider voltage is then the same as the voltage at the junction of R35/R36). On receipt of a signal, AGC applied to the grid of V6 causes a reduction in screen current which results in the voltage at the junction of R35/R36 going more positive, unbalancing the bridge network and so causing the meter to read. The circuit is quite sensitive and the meter can be used either as a tuning indicator or for comparing the strength of received signals. The scale is calibrated in arbitrary divisions 0-10.

The output circuit of the last 100 kc/s transformer T4 feeds the Cathode Follower (V8), the two diodes of V9 and the CW/SSB Detector V13. The Cathode Follower employs a triode-strapped 6AU6 (EF94) and provides a low impedance output at 100 kc/s for feeding ancillary units (FSK adaptors etc.). The output can be terminated in any impedance in the range 75-300Ω.

One diode of the 6AT6 (EBC90) which is used in the V9 position serves as the AM Detector while the other is used for AGC. The detector is conventional and incorporates a series diode noise limiter (V7) to reduce impulse noise during AM reception. A double-diode (6AL5/EB91) with both diodes strapped is used as the limiter. S4a (part of the combined AGC/RL switch) is arranged to take V7 out of circuit when not required. Audio output from the AM Detector is taken to the 'AM' position of the Mode Switch wafer S5a for routing to the Audio Section.

AGC is delayed by the voltage developed across R52 which together with R50 forms a potential divider across the main HT supply. The delay is applied in the cathode of V9 and is reduced by switching R49 across R52 when the Mode Switch is moved to the 'SSB' positions. This is done to maintain efficient AGC action with the reduced average sideband power available for the production of AGC bias when taking 'SSB' signals. At the same time, the discharge time constant of the AGC circuit is increased to approximately 10 seconds to prevent noise bursts during breaks in transmission. This is achieved by S5b which introduces C116 (10 μ F). AGC is applied to the RF Amplifier, 1st Mixer and both 100 kc/s IF Amplifiers and is brought out for diversity use at SKT3/3. For manual gain control, the AGC is taken out of operation by S4b which grounds the AGC line.

The CW/SSB Detector V13 employs a 6BE6 (EK90) pentagrid in a single valve product detector circuit and gives superior results to those obtained with the more conventional diode/BFO arrangement. The signal (IF) input is applied at g3 and the oscillator at g1.

The same oscillator is used for both carrier re-insertion on 'SSB' and as a BFO for 'CW' working. Adjustment of the oscillator frequency is achieved by the capacity diode (D1 : 10OSC2) which is wired in parallel with the oscillator tuned circuit. D1 is biased in the reverse direction by applying a positive voltage to the cathode via R86, which with C181 forms a filter to prevent oscillator leakage along the DC control line to the appropriate section of the Mode Switch S5e. The cathode of D1 is grounded to RF by the 0.1 μ F capacitor C180.

The controlling bias for the diode is derived from three separate divider networks which are connected across the HT4 stabilised supply. When the Mode Switch is in the 'CW' position, the diode is biased from the potentiometer RV5 which serves as the BFO Pitch adjustor and gives an approximately linear change in frequency over a swing of the order ± 3 kc/s.

With the Mode Switch at 'SSB', control bias is taken from the slider of either RV6 or RV7 depending on the sideband selected. In the 'UPPER' position, RV6 provides a bias such that the oscillator is tuned to approximately 101.5 kc/s. This may at first sight seem wrong but it must be remembered that a signal inversion occurs during the first frequency conversion so that an upper sideband signal becomes a lower sideband signal at the 1st IF and therefore calls for carrier re-insertion on the high side. Inversion does not occur in the second stage of conversion because in this case the local oscillator is on the low frequency side of the 1st IF.

When S5 is moved to the 'LOWER' position, RV7 places the oscillator on a frequency of approximately 98.5 kc/s and the voltage applied to the diode in this case will be less than that obtained from RV6 in the other position. This is because the capacity of the diode decreases with increasing voltage.

RV5 remains in circuit in the 'SSB' positions of S5 but its control range is reduced to something of the order ± 100 c/s by introducing the 0.1M Ω resistor R87. This gives very fine control of the actual re-insertion frequency and makes the tuning of 'SSB' signals an extremely straightforward procedure.

A filter is incorporated in the output from V13 to prevent the oscillator and IF signal components which appear at the anode from reaching the audio stages and so causing instability. The filter comprises R85, C175 and C176 and audio is taken from its output via C177 to the CW/SSB positions of the Mode Switch wafer S5a. A further section of the same switch (S5d) is arranged to apply stabilised HT (HT4) to the screen of V13 when receiving CW/SSB signals.

Output from the appropriate detector is selected by the Mode Switch and is applied via C112 to the AF Gain control RV4. The slider on this control feeds the grid of the Audio Amplifier which is the triode section of the double-diode-triode V9. It will be noticed that the grid resistor R44 is returned to the junction of R52/R53 so that the bias applied is that developed across R53. The junction of R52/R53 is grounded to AF by C115 (25 μ F).

V9 is resistance-capacity coupled to the Audio Output Stage V10 which employs a 6AQ5 (EL90) beam tetrode in a conventional circuit. The output transformer T5 has two secondary windings, one at 2.5/3Ω to feed an external loudspeaker and the other at 600Ω for connection to remote lines linking the receiver to a distant listening point. This latter winding is electrostatically screened from the primary and the other secondary and has a centre-tap which can be earthed to provide a balanced output.

The telephone socket (JKL) is tapped into the divider network R59/R60 which is fed direct from the anode of the output valve via the blocking capacitor C122. The arrangement allows telephones of almost any impedance to be used with quite satisfactory results although optimum results will be secured with 'phones of about 2000Ω impedance. A spare contact on JKL interrupts the speaker output but not the 600Ω output when telephones are in use.

THE POWER SUPPLY SECTION

The main item in the power supply is a high grade 'C' core power transformer which provides three separate LT outputs (only two of which are used) and has a centre-tapped secondary winding giving 250-0-250 volts. HT rectification is by silicon diodes (either 4 x DDO06 or 2 x DDO58) which are used in a standard full-wave circuit. Smoothing is provided by the capacity input filter which comprises the choke CH1, the 50μF electrolytic capacitor C194 and one 32μF section of C192. The other section of C192 is fed from the main HT output (HT1) via R99 to provide a well decoupled supply (HT2) for the anodes of V9 and V13.

Two separate stabilised supplies are provided (both of 150V) and these are utilised as follows:- HT3 feeds the screen of the 2nd Mixer and both the 1st and 2nd Local Oscillators. HT4 is used for the screen of V13 (CW/SSB Detector) and also for the three potential divider networks which control the capacity diode D1.

Both LT supplies provide 6.3V, the main supply (LT1) having an earthed centre-tap and feeding all LT circuits except the heater of the Noise Limiter V7 which is fed from the LT2 supply. The centre-tap of LT2 is returned to the divider network R97/R98 and this maintains the heater of V7 at a few volts above ground to prevent hum being introduced at this point in the circuit. This avoids the need for special selection of the 6AL5 for use in this position.

The low voltage secondary windings on the power transformer are not taken directly to the heater circuits but are wired to four connections on the 12-way male socket SKT5, (Nos. 1 & 2 and 10 & 11). The two heater circuits are terminated at four of the remaining connections of SKT5 (4 & 5 and 7 & 8) and the circuits are completed by links on the female plug PL3 which for normal mains operation must be in position at SKT5. This arrangement provides complete isolation for the transformer secondary windings when an AC supply is not available and the heater circuits are strapped together and fed from an external 6V supply, (see wiring of PL2 on circuit diagram). Also terminated at SKT5 is a lead from the input side of the HT smoothing circuit which allows an externally derived HT supply to be fed to the receiver. An earth is provided on pin 12 and it should be noted that the internal smoothing circuit is used to supplement the filtering in the external supply unit.

The same connections referred to in the previous paragraph can also be used for extracting HT and LT supplies from the receiver to power small external units. The plug in this case would be wired as PL3 on the circuit diagram.

The mains input to the power transformer is fused at 2 Amps and switched by the double-pole Mains Switch S7. (1.5 Amps Thermal Storage Delay Fuse is used on 830/2).

THE CRYSTAL CALIBRATOR

A 6AU6/EF94 is used for this stage (V11) which is housed in a small diecast box located on the cover over the main tuning gang. The unit provides markers at 100 kc/s intervals throughout the complete range of the receiver and can also be used to check the accuracy of the incremental scale.

The crystal is of the same frequency as the 2nd IF and sufficient calibrator signal is leaked into this part of the circuit to obviate the need for introducing the BFO when making a calibration check. Harmonic injection is at the grid of the 1st Mixer by proximity coupling to the gang wiring, while injection at the 2nd IF is due to direct radiation of the fundamental within the receiver.

The calibrator is brought into operation by pressing the small button switch S2 which applies HT to the calibrator unit and at the same time introduces R4 in the cathod circuit of the RF Stage to limit interference from outside signals when a calibration check is being carried out. Scale correction is by lateral movement of the cursor independently of the main tuning control.

Supplies are fed to the calibrator via PL1/SKT4 and harmonic output is from a wire projecting from the underside of the diecast housing. The crystal can be standardised against any standard frequency transmission by adjusting C127 which is wired across the crystal.

CONSTRUCTIONAL DETAILS

Dimensions and Weight.

Width	16.3/4"	42.5 cm.
Width with rack-mounting brackets	19"	48.3 cm.
Height	8.3/4"	22.2 cm.
Height with shock-mounts	9.7/16"	24.0 cm.
*Depth	13.19/32"	34.5 cm.
*Depth behind brackets (rack-mounting)	11.27/32"	30.1 cm.
Weight (standard 830)	49 lb.	22.2 kg.
Weight (830/RM)	50 lb.	22.7 kg.
Weight (830/RM less cabinet)	39 lb. 8 oz.	18.1 kg.
Weight (standard 830 with shock-mounts)	50 lb. 4 oz.	22.8 kg.

Cabinet.

The type of cabinet provided with the Model 830 depends on the method of mounting which is to be employed. Cabinets are available for rack or surface mounting. Both types are basically the same but the rack-mounting version has cut-outs along the leading edges of the vertical sides. These cut-outs extend approximately $\frac{1}{2}$ " back from the panel and give clearance for the two angled brackets which are attached to the rear of the panel to allow the receiver to be mounted in the rack. The brackets are provided with fixing slots which conform to the Post Office standard for racks of 19" width.

If the equipment is to be used in a position which is likely to be subject to excessive vibration (as for example in a mobile installation), shock-absorbent mounts can be attached to anchor points on the underside of the cabinet. This applies to both types of cabinet so that an 830/RM can be surface-mounted with shock-absorbers if this should be necessary.

*Excluding projections at rear of cabinet (plugs etc.).

Either form of cabinet has extensive perforation to ensure adequate ventilation. Three apertures at the rear allow easy access to the various sockets and the pre-set meter zero control etc. The cabinet is made of steel, suitably rust-proofed and enamelled.

Front Panel.

The front panel is an aluminium diecasting and contributes great mechanical strength to the receiver as a whole. All controls except the cursor adjuster are located along the lower half of the panel and their functions are indicated on a clearly marked finger plate. The chromium-plated panel handles allow the receiver to be lifted easily and also afford protection to the panel controls when the receiver is placed in a face-down position as for example when removing the cabinet.

Chassis Assembly.

The internal lay-out of the receiver is dictated mainly by the use of a diecast 'coil box' which serves as the chassis for the complete RF Section and is mounted centrally behind the panel. Two sub-chassis occupy the space remaining on either side of the RF Unit and these are attached to this central unit and also to two steel end-plates at the extreme ends of the panel.

When the receiver is viewed from the front, the sub-chassis in the right-hand position carries all the power supply components and also has mounted upon it a small screened box which houses the complete 1st IF and 2nd Local Oscillator Stages. In the left-hand position is the 2nd IF chassis which also includes the audio stages etc. The built-in calibrator is housed in a small diecast box which is mounted on top of the gang cover on the RF chassis.

Main Dial and Drive Assembly.

The main tuning control which drives a spring-loaded split-gear system having a reduction ratio of approximately 140:1 gives a tuning rate which varies between 2.5 kc/s per rev. at 300 kc/s and 250 kc/s per rev. at 30 Mc/s. The drive is flywheel-loaded, substantially free from backlash and ensures consistent re-setting accuracy at all frequencies. Total cursor travel on each range is some 13 inches and the scales are calibrated directly in frequency (kc/s below 1.5 Mc/s and Mc/s above this frequency). The cursor can be moved independently by means of a mechanical adjuster which provides scale correction when calibrating against the built-in crystal calibrator.

Incremental Tuning.

This control requires approximately 20 revolutions to cover the complete swing of 200 kc/s, so giving an average tuning rate of approximately 10 kc/s per rev. The drive is through spring-loaded split-gears to ensure that backlash is kept within the smallest possible proportions.

The incremental calibration appears in an aperture above the main scales and the 'off-tune' direction (i.e. + or -) is indicated by printing the scales in different colours. Calibration in red shows that the receiver is tuned to a frequency higher than that given by the main scales. Black figures indicate a lower frequency.

INSTALLATION

MOUNTING

Unless otherwise stipulated, the Model 830 is supplied complete with a standard cabinet in a form suitable for surface-mounting only. An interchangeable cabinet is available to special order and this has slots to clear the angled brackets which are fitted to allow the receiver to be mounted in a standard 19" rack. Receivers of the 830 type supplied initially as rack-mounting units are referred to as 830/RM, 830/1/RM and 830/2/RM. In rack-mounted installations operating at elevated temperatures it may be an advantage to remove the cabinet.

If required, either type of cabinet can be attached to shock-absorbent mounts which can be ordered separately by quoting LP2817. Mounts are supplied in pairs complete with all washers and fixing screws and attach to the underside of the cabinet in each case.

Converting a Standard 830 to 830/RM.

1. Remove the existing cabinet (four large screws at the rear) and store for use in the event of the receiver being required as a surface-mounted unit at a later date.
2. Place the receiver on its left-hand side and remove the two screws that hold the right-hand panel handle (an 18" screwdriver will be found most suitable for this operation).
3. Remove the two spacing washers from between the sideplate and the panel (store with the cabinet).
4. Slide one of the two angled brackets between the panel and the sideplate and replace the handle fixing screws.
5. Turn the receiver up the other way and repeat the operations described above in fitting the angle bracket at the left-hand side of the panel.
6. Fit the replacement cabinet.

NB Part Nos. to be quoted when ordering rack-mounting cabinets and brackets are 5911/1P and 5912P respectively.

Method of fitting shock-absorbent mounts.

1. Place the receiver upside-down.
2. Take the large neoprene washers and place these over the fixing holes in the underside of the cabinet (stepped face uppermost).
3. Lower the channel shaped mounting brackets onto the washers, keeping the fixing flange towards the outside of the receiver and at the same time making sure that the step on the washers locates with the holes in the brackets.
4. Place the smaller neoprene washers on the inside of the channel and pass the 2BA screws with brass washers through both neoprene washers.
5. Locate screws in hank bushes in cabinet and tighten.
6. Fix channel mounting brackets to bench top with suitable screws.

NB If the brackets are mounted on a metal surface, make sure that they are well bonded to this surface.

EXTERNAL CONNECTIONS

Mains.

The AC mains supply is connected to the socket at the rear using the connector provided with the receiver. The earthing wiper on the side of the connector should be wired to the earth pin of the supply plug.

In the case of the 830/2 receiver, the mains connector is a non-reversible type and is supplied with a lead attached. This is left free at one end so that the user can fit a plug of a type suitable for connection to the local supply. The red wire should be connected to the live side of the mains, black to neutral and the green wire to earth.

The receiver leaves the factory with the power transformer set for 240V AC operation. If the receiver is to be operated from any other supply voltage the tapings on the power transformer must first be set as indicated in the Table below. This must be done before the receiver is connected to the supply.

Under no circumstances should the receiver be connected to a DC mains supply.

Voltage	Strap	Input to	Voltage	Strap	Input to
100	C & D	C & H	200	D & E	C & H
	E & H		210	D & F	C & H
110	C & D	C & G	220	D & F	C & G
	F & G		230	A & E	B & H
115	A & B	B & H	240	A & E	B & G
	E & H		250	A & F	B & G
125	A & B	A & G			
	F & G				

Shorting Plug.

The receiver LT circuits are interrupted at the male socket SKT5 to facilitate operation from external power supplies. These circuits must be completed during normal mains operation by links in a 12-way female connector mating with SKT5. This connector is shown as PL3 on the circuit diagram at the rear of the Manual and is supplied ready wired with links between connections 1 & 4, 2 & 5, 7 & 10 and 8 & 11.

Ancillary Supplies.

If the receiver is operating from the mains, HT and LT supplies are available at PL3 for operating small ancillary units. The available outputs should be limited as follows:

HT	250V @ 15mA	(unsmoothed).
LT	6.3V @ 1.2A	(balanced supply with earthed centre-tap).

Connections should be made as follows:

HT+	pin 9.	LT	pins 10 & 11.
HT-	pin 12.			

External Power Supplies.

Provision is made for operating the 830 receiver from externally derived HT and LT supplies when an AC mains supply is not available. The voltages required are 250V @ 160mA for HT and 6 or 6.3V @ 4.8A (approx.) for LT.

The HT supply can be derived from any convenient source but a transistorised converter is recommended because of its higher efficiency. LT can be taken straight off a 6V accumulator or tapped from a battery of higher voltage.

A 12-way female connector is required to mate with SKT5. If an extended period of operation from external power supplies is envisaged this can be the existing shorting plug supplied with the receiver. On the other hand, when the arrangement is for emergency working in the event of mains failure, an extra connector should be obtained. The wiring of the connector is given at PL2 on the circuit diagram at the rear of the Manual and the connections are summarised below:

HT+	pin 9.	LT+	pin 4.
HT-	pin 12.	LT-	pin 8.

Links must be in position between pins 4 & 7 and 5 & 8 to combine the two separate LT circuits (LT1 and LT2), while a further link is required between pins 8 & 12 to earth one side of the LT circuit. It should be noted that the LT supply can be operated with a positive earth if this should be found more convenient.

If screened cable is used for the supply leads, the braid can be conveniently earthed at pin 12 of the connector. Heavy gauge wire should be used for the LT connections and both HT and LT supplies should be switched and fused at their source.

Reference to the circuit diagram will show that the external HT is taken via the existing smoothing circuit to supplement the smoothing in the external supply unit. Stabilised HT supplies are available as during normal mains operation.

Aerial.

The nominal aerial input impedance is 75Ω and connection is by means of a coaxial plug which is supplied with the receiver.

The type of aerial system used will obviously depend on the application for which the receiver is required. A dipole aerial fed with 75Ω coaxial cable can be connected directly at the aerial input socket and will give excellent performance over a wide band centred on the design frequency. Operation of the dipole on its harmonics is also feasible. Coaxial feed without the need for a balun at the aerial end is quite satisfactory, although use of a balun may result in less local noise pick-up on the feeder at frequencies higher than perhaps 20 Mc/s.

When more complex systems, or aerials of random length are used, the feed impedance will most likely be well removed from 75Ω . Performance under these conditions, although not optimum will in many cases be quite satisfactory and there will be no need to introduce external matching. If however, optimum performance is required, improved results can be obtained with very simple L/C matching circuits. These can be either remotely located at the aerial or situated directly at the receiver input.

Earth.

Although the receiver chassis is grounded as a safety measure by virtue of the 'supply earth', the efficiency of this connection may be extremely poor from the point of view of reception. It is recommended therefore that wherever possible a more direct earth is connected to the terminal provided at the rear of the receiver.

A good earth connection will do much to reduce the high level of local noise which can impair reception on the lower frequencies. The earth lead should be kept as short as possible using heavy gauge wire and the outside connection to the earth pin or plate must be well protected against corrosion.

When the receiver is powered from a source which includes an earth leakage trip, a check should be made to see that the operation of this device is not affected by the direct earth connection.

Loudspeaker.

An external loudspeaker can be connected to the 12-way male connector PL4 which mates with SKT3 at the rear of the receiver. A standard 2.5/3Ω speaker is required and this should be wired to connections PL4/7 and PL4/9. PL4/7 is the earthy side of the output which is directly at low impedance to avoid the need for an external transformer.

Suitable loudspeaker units in the EDDYSTONE range are covered in Data Sheet No. 123 a copy of which is available on request.

Line Output.

A 600Ω line output is available at PL4/10 and PL4/12 for use when the receiver must be linked to a distant listening position. If necessary, the output can be balanced by connecting the centre-tap of the output winding to earth. This can be done at PL4 by soldering a wire link between connections 7 and 11.

Should an attenuated 600Ω output be required, this can be arranged by wiring a resistive attenuator inside the plug housing. Connections 2, 5 and 8 are not wired and can be used as anchor points for the components.

To obtain a combined audio output in a dual diversity installation, the Line Output connections should be wired as follows:

1. Connect a 150Ω $\frac{1}{2}$ watt resistor across PL4/10 and PL4/11 of the Control Receiver.
2. Connect a 150Ω $\frac{1}{2}$ watt resistor across PL4/11 and PL4/12 of the Slave Receiver.
3. Link PL4/12 of the Control Receiver to PL4/10 of the Slave Receiver and earth this connection to PL4/7 of either receiver if a balanced output is called for.
4. Take output from PL4/11 on both the Control and Slave Receivers.

Diversity AGC.

When receivers are operated in diversity it is usual to link their AGC lines together so that the receiver providing the highest signal level will silence the noise output of the other receiver(s).

Provision is made for linking the AGC lines of 830 receivers operating in diversity installations by bringing the AGC out at SKT3. Connection can then be made to the 12-way connector PL4 which mates with SKT3. Screened wire should be used for the inter-connecting lead, the inner of which is wired to PL4/3 and the braid to the associated earth at PL4/6.

Muting.

When the 830 receiver is used in close proximity to an associated transmitter it will be necessary to reduce the gain of the receiver to prevent overload, feedback etc. while the transmitter is radiating. This can be achieved by incorporating an extra switch or relay contact in the existing send/receive switching arrangements and wiring this to the 12-way connector PL4 which mates with SKT3. The connections are to PL4/1 and PL4/4 (earth) and the external switching should be arranged to close the circuit on 'receive' and open on 'transmit'. In the latter condition, a 47,000Ω resistor (R77) is introduced in series with the cathode returns of the RF and 1st 100 kc/s IF Amplifiers. The additional bias developed across this resistor is used to effectively mute the receiver.

With this arrangement, monitoring of the outgoing transmission will not be possible and if this facility is required it will be necessary to have some control over the gain reduction obtained in the transmit condition. This can be arranged quite simply by wiring a 50,000Ω variable resistor in parallel with the external switching. The resistor will function as a combined RF/IF Gain control and will therefore provide a wide variation in the sensitivity.

If the power output and siting of the associated transmitter are such that a voltage greater than 20V appears across the aerial coils, a further relay should be arranged to short down the aerial input to prevent possible damage to the windings.

When the muting facility is not required, PL4/1 and PL4/4 must be linked together with a wire strap to complete the cathode circuits of V1 and V5. Otherwise the receiver will be continuously muted.

A small iron-cored inductor (CH2) can be fitted to special order to reduce clicks during keying. Fixing points for CH2 are included as standard so that existing receiver can be modified if required. Spares No. 6461P should be quoted when ordering the choke which is supplied with an instruction sheet giving details for installation.

IF Output.

Connection to this output is by means of a standard BNC connector which is supplied with the receiver. The nominal output impedance is 250Ω and is suitable for use with terminating impedances in the range 75- 300Ω . The output frequency is 100 kc/s and the maximum bandwidth 6 kc/s at 6dB down.

Telephones.

The output provided for telephone use is suitable for a wide range of impedances so that almost any available pair of telephones will give satisfactory results. If optimum performance is required telephones of 2000Ω (total) impedance should be used. An auxiliary contact on the jack socket is arranged to interrupt the loudspeaker output when telephones are in use.

OPERATION

CONTROL FUNCTIONS

Main Tuning.

This control is conveniently positioned for ease of operation and will in most cases be used for all general tuning. The main calibration (in kilocycles below 1.5 Mc/s and in megacycles over the range 1.5-30 Mc/s), can be read without parallax effects by use of the specially designed cursor.

The drive is flywheel-loaded to allow rapid movement from one end of a range to the other and has a reduction ratio of approximately 140:1 to maintain ease of adjustment even at the highest frequencies where a tuning rate of some 250 kc/s per revolution is obtained.

It must be borne in mind that on Ranges 1-6 the receiver operates as a double conversion superhet with a 1st IF that can be tuned over a range 100 kc/s either side of its nominal centre frequency. When the MAIN TUNING is used alone therefore, it is essential that the INCREMENTAL TUNING is set to the centre of its range or otherwise the main scale calibration will be in error.

Wavechange Switch.

Selects the appropriate inductances for the range in use and converts the circuit for double conversion working on Ranges 1-6. Range indication is provided by suitable marking (1-2-3 etc) on the finger plate concentric with the control knob. This same numbering appears at the left-hand end of the main tuning scales.

Crystal Selector Switch.

This is located at the rear of and concentric with the WAVECHANGE SWITCH. It has

nine positions which are labelled M - A - B - C - D - E - F - G - H. In the first position (M) the receiver is arranged for normal 'Manual' tuning and the Crystal Oscillator is disabled by the switching system. When the switch is moved to any of the other positions the normal local oscillator is taken out of circuit and one of the eight crystals is brought into operation. Under this condition of operation the MAIN TUNING is used only to align the RF and 1st Mixer circuits on the appropriate signal frequency.

Incremental Tuning.

Provides electrical bandspread over a 200 kc/s band centred on any signal frequency in the range 1.5-30 Mc/s. The effective tuning rate is constant at all frequencies and the calibration is directly in kilocycles.

Calibration appears in red when the tune frequency is higher than that indicated on the main scale and black when the frequency is lower. The INCREMENTAL TUNING must be set to the centre of its range when the MAIN TUNING is used alone. Failure to observe this rule will result in errors in the main scale readings.

Peak RF Control.

This provides a means of correcting the misalignment of the bandpass input and 1st Mixer circuits which occurs when the 1st IF is detuned from its nominal frequency by the INCREMENTAL CONTROL. The control operates three ganged capacitors in parallel with the signal frequency sections of the main tuning gang. The maximum capacity of this additional tuning gang has been kept as low as possible to avoid too sharp a tuning characteristic on Range 1. Full correction is possible at frequencies above 3 Mc/s on Range 5 and above 2 Mc/s on Range 6.

Gain Controls.

Three totally independent gain controls are provided as follows:

RF GAIN	varies the bias on the RF Amplifier V1.
IF GAIN	varies the bias on the 1st 100 kc/s IF Amplifier V5.
AF GAIN	controls the output from the appropriate detector.

The RF and IF GAIN CONTROLS are operated by means of concentric control knobs; the outside knob (with red index) is the RF GAIN.

Signal Mode Switch.

The SIGNAL MODE SWITCH is a four-position control which carries out all circuit changes required for the various modes of reception. The four positions are marked:

'AM' - 'CW' - 'SSB UPPER' - 'SSB LOWER'

In addition to selecting output from the appropriate detector etc. the SIGNAL MODE SWITCH also modifies the AGC arrangements when set to either of the 'SSB' positions. Under this condition of operation the delay is reduced to secure better AGC action and the discharge time constant is lengthened to approximately 10 seconds.

BFO Pitch.

This control is operative in both the 'CW' and 'SSB' positions of the SIGNAL MODE SWITCH. On 'CW' it provides a swing of approximately ± 3 kc/s and functions as a normal 'pitch adjustor'. It should be noted that this control, being a potentiometer as opposed to the more conventional capacitor, has a swing of some 270 degrees for this range of adjustment.

When the SIGNAL MODE SWITCH is moved to either of the 'SSB' positions, control voltage for the capacity diode which tunes the BFO is derived from one of the two pre-set potentiometers which are located on the main IF/AF chassis. The BFO PITCH ADJUSTOR

remains in circuit on 'SSB' but has a very much reduced control swing (± 100 c/s). This permits precise and relatively easy adjustment of the carrier re-insertion frequency in 'SSB' reception.

Selectivity.

The SELECTIVITY CONTROL provides continuously variable adjustment by physical movement of the 100 kc/s IF coils. The control arc is marked 'AM' - 'SSB' - 'CW' so that the bandwidth can be set rapidly to suit the received signal. A click-stop is provided for accurate selection of the correct bandwidth required for 'SSB'. The extreme 'CW' position is marked 'N' (narrow) and when the control is set to this mark, the 100 kc/s crystal filter is automatically brought into circuit. A second click-stop ensures positive selection of the 1.3 kc/s CW bandwidth.

AGC/Noise Limiter Switch.

Combined AGC and Noise Limiter switching is provided by a 3-position switch.

Posn. 1	. . .	AGC : ON,	NL : OFF.	Posn. 3	. . .	AGC : ON,	NL : ON
Posn. 2	. . .	AGC : OFF,	NL : OFF.				

The AGC time constant is fixed for AM/CW reception and is increased by the SIGNAL MODE SWITCH when this is set to 'SSB'.

The Noise Limiter is only operative when the SIGNAL MODE SWITCH is at 'AM'. On 'CW' and 'SSB' a high degree of limiting is inherent with the type of detection employed.

Calibrator Switch.

This is a double-pole switch with one 'make' and one 'break' contact. On pressing the plunger, HT is applied to the Calibrator Unit and at the same time the gain of the RF Stage is drastically reduced to limit interference from outside signals.

Crystal controlled markers are available at all 100 kc/s points throughout the entire tuning range of the receiver and also at the 50 kc/s points on the incremental scale. Calibration will normally be carried out with the SIGNAL MODE SWITCH in the 'AM' position, this being possible because the fundamental crystal frequency coincides with the 2nd IF (100 kc/s).

Cursor Adjustor.

This is a small knurled control located above the dial aperture. It provides limited lateral movement of the cursor (independently of the MAIN TUNING CONTROL) to allow correction of scale errors when calibrating.

Mains Switch.

A double-pole switch which breaks both live and neutral poles of the mains supply to the receiver. The switch performs no function when the receiver is powered from external HT and LT supplies.

Meter Zero.

This control is located at the rear of the receiver and provides a means of setting the meter needle to zero before making comparative checks on carrier level.

Telephone Output.

The telephone output socket is located at the right-hand side of the finger plate and accepts a standard Post Office type telephone plug.

The output impedance is 2000 Ω but other impedances can be used quite satisfactorily.

TUNING INSTRUCTIONS

Manual Tuning.

1. Set the following controls as indicated:-

CRYSTAL SELECTOR SWITCH	Manual (M).
SIGNAL MODE SWITCH	'AM' - <u>BFO is not required for calibration</u>
RF GAIN CONTROL	Any setting. <u>check.</u>
IF GAIN CONTROL	Reduce as necessary to prevent detector over- load when making the calibration check as des- cribed below.
AF GAIN CONTROL	Approximately half of maximum setting.
INCREMENTAL TUNING	To centre of range ('0'). This step is not required if operation is to be on Ranges 7, 8 or 9.
SELECTIVITY	'CW'.
AGC/NL SWITCH	Off (centre position).
PEAK RF CONTROL	Index at 12 o'clock.

2. Select the appropriate range with the WAVECHANGE SWITCH and tune to the nearest crystal check point to the required working frequency (MAIN TUNING CONTROL).

NOTE Crystal check points occur at 100 kc/s intervals, e.g. the following frequencies are check points on Range 9 : 300, 400 and 500 kc/s. On Range 6 : 1.5, 1.6, 1.7, 1.8, 1.9 Mc/s etc., etc.

3. Carry out a calibration check by following the instructions given below:-

- (a) Press the CALIBRATOR SWITCH and tune in the appropriate marker signal with the MAIN TUNING CONTROL.
- (b) Adjust the MAIN TUNING CONTROL until the marker signal is at zero-beat. Do not disturb the setting of this control while continuing as follows:
- (c) Rotate the CURSOR ADJUSTOR to position the cursor coincident with the appropriate calibration mark on the main scale.
- (d) Release the CALIBRATOR SWITCH and tune with the MAIN TUNING CONTROL to the required working frequency.

NOTE The calibration check can be carried out in the 'CW' mode but the BFO PITCH ADJUSTOR must then be set to the centre of its range. Calibration should not be attempted in the 'SSB' positions of the SIGNAL MODE SWITCH.

4. The receiver is now ready for use. Any re-adjustment of the control settings should be carried out to suit the mode of reception and the conditions prevailing. Further instructions are given later in this Section on the methods to be adopted in tuning 'SSB' signals etc.

*Incremental Tuning.

The advantages offered by this facility when using 'Manual' control in conjunction with the Crystal Calibrator are that (a) frequencies can be set accurately to within 1 kilocycle, and (b) a constant tuning rate is available at all frequencies within the range 1.5-30 Mc/s.

The incremental scale is marked at 1 kilocycle intervals and has calibration figures every 10 kc/s. Two-colour printing is used to indicate whether the effective tune frequency is higher or lower than that indicated on the main scale. The

*Refer to Appendix 'A'.

calibration figures run in the following sequence with those underlined appearing in RED and the others in BLACK.

100 - 90 - 80 30 - 20 - 10 - 0 - 90 - 80 - 70 20 - 10 - 0

Calibration in RED indicates that the receiver is tuned to a frequency higher than that given by the cursor while BLACK figures show a lower frequency.

Although the INCREMENTAL TUNING CONTROL will provide coverage of a band 200 kc/s wide centred on any frequency in the range 1.5-30 Mc/s, it is suggested that the 'band centre frequency' chosen should always be a crystal check point. If this procedure is adopted setting up is easier and frequencies can be determined much more readily than if the centre frequency is a random figure.

Take as an example a receiver tuned to a band centre frequency of 2.7 Mc/s. The incremental coverage in this case will be the band 2.6-2.8 Mc/s and from the notes given previously it is immediately obvious that if the incremental reading is in BLACK then the effective tune frequency must lie in the range 2.6-2.7 Mc/s. The effective tune frequency would lie in the range 2.7-2.8 Mc/s only if the calibration appears in RED.

Because of the manner in which the incremental scale calibration is presented, the effective tune frequency is determined merely by combining the incremental reading with the lowest frequency in the 100 kc/s segment indicated by the colour of the incremental scale. If, for example, the incremental scale reads '24 BLACK', this would show that the receiver is tuned to a frequency 24 kc/s higher than the lowest frequency in the low frequency segment, i.e. the effective tune frequency is 2624 kc/s. Similarly a RED reading of '92' represents an effective tune frequency of 2792 kc/s.

Once an operator becomes familiar with the receiver, calculation will become nothing more than a subconscious process because the 'BLACK 0', (continuing the example above) would automatically be accepted as 2600 kc/s and the 'RED 0' as 2700 kc/s.

As mentioned previously, the incremental facility will give coverage of a 200 kc/s range centred on any frequency. A special case which requires consideration is when setting up for coverage of a range, the end frequencies of which fall exactly half way between adjacent crystal check points on the main scale. The band 2650-2850 kc/s is an example in this category.

As in the previous case, the cursor setting must always be to the band centre frequency which in this example is 2750 kc/s. If the main scale is first calibrated against the crystal marker on 2700 kc/s, with the incremental scale set to '0', then it will be possible to set the main scale to 2750 kc/s with a fair degree of accuracy by visual interpolation. Re-setting the incremental scale to '50 BLACK' will now give an approximate tune frequency of 2700 kc/s.

Switching on the Calibrator at this stage results in two harmonics of the crystal being heard simultaneously. One is the harmonic at 2700 kc/s and the other is one of the two harmonics which fall within the range of the tunable IF (actually the one at 1400 kc/s).

The IF harmonic can be identified quite easily by detuning the MAIN TUNING CONTROL to eliminate the 2700 kc/s marker. It should be appreciated that the appearance of the harmonic at 1400 kc/s is inherent in the design of the receiver and though put to good use in crystal controlled operation of the receiver (see later) there is no intention that this marker (or the one at 1300 kc/s) should be used during normal working except in as much that they allow a rapid check on the accuracy of alignment of the 2nd Local Oscillator. This example is dealt with here only to preclude the possibility of confusion which may arise due to non-familiarity with the equipment. If this situation is encountered in normal operation, set the incremental scale visually to the 50 kc/s mark and ignore the IF marker signal. Any slight error is eliminated when the 2700 kc/s marker is adjusted to zero-beat with the MAIN TUNING CONTROL.

Peak RF Control.

When the incremental facility is used as described in the paragraphs above, the MAIN TUNING CONTROL is pre-set to provide a fixed injection frequency to the 1st Mixer Stage. As a result, any off-tuning with the INCREMENTAL TUNING CONTROL will result in misalignment of the signal frequency circuits. These however can be tuned independently by the PEAK RF CONTROL and should always be adjusted for maximum signal in much the same way as when setting the 'aerial trimmer' on other communication receivers.

The value of the 'peak-RF' capacitors has been kept as low as possible to avoid too sharp a tuning characteristic on Range 1. Full correction is possible at frequencies above 3 Mc/s on Range 5 and above 2 Mc/s on Range 6.

On Ranges 7, 8 and 9, the 'peak-RF' capacitors remain in circuit and should be set for maximum signal in the usual way.

Crystal Controlled Operation.

The 830 receiver can be operated with either or both Local Oscillators crystal controlled for high stability multi-channel working on frequencies above 1.5 Mc/s.

Crystal control of the 2nd Local Oscillator results in loss of the incremental facility and would normally be contemplated only in the case of an unattended installation operating with full crystal control.

In this case, a standard Style 'D' crystal suitable for series mode operation whose frequency falls in the range 1150-1350 kc/s can be fitted in the holder provided. Access to this is by removal of the top cover from the screening box which houses the second conversion stages. The holder is normally shorted by a wire link and this must be unsoldered and removed for crystal operation. It must be replaced should 'Manual' operation be required at a later date.

In the unlikely event of the 2nd Local Oscillator being controlled alone, the crystal frequency should be chosen as 1250 kc/s so that the 1st IF lies at the centre of its range (1350 kc/s) to ensure correct calibration of the main scale. With full crystal control this is of no consequence and the 1st IF can be controlled anywhere in its 200 kc/s range.

The Table given below shows the appropriate settings for the incremental scale for various crystal frequencies. The scale must be set as indicated to ensure correct operation of the crystal and also to align the tunable IF circuits to the appropriate channel. The 1st IF is included in the Table as a reminder that this frequency increases for a decrease in effective tune frequency and also for reference when considering crystal control of the 1st Local Oscillator Stage. Slight pulling of the 2nd Oscillator crystal is possible by fine adjustment of the INCREMENTAL TUNING CONTROL.

Crystal Freq.	Inc. Setting 830 & 830/1	Inc. Setting 830/2	1st IF
1150 kc/s	100 RED	100 RED	1250 kc/s
1175 kc/s	75 RED	75 RED	1275 kc/s
1200 kc/s	50 RED	50 RED	1300 kc/s
1225 kc/s	25 RED	25 RED	1325 kc/s
1250 kc/s	0 RED	0 BLACK	1350 kc/s
1275 kc/s	75 BLACK	25 BLACK	1375 kc/s
1300 kc/s	50 BLACK	50 BLACK	1400 kc/s
1325 kc/s	25 BLACK	75 BLACK	1425 kc/s
1350 kc/s	0 BLACK	100 BLACK	1450 kc/s

The 1st Local Oscillator can be crystal controlled for reception on any frequency above 1.5 Mc/s. At frequencies above 3 Mc/s the injection frequency can be either above or below the signal but below 3 Mc/s the oscillator must be operated on the 'high' side. This is to allow the use of standard crystals and also to avoid placing the oscillator frequency within the coverage of the tunable IF. Crystals are standard Style 'D' units for parallel mode working and the injection frequency (except for frequencies in the range 1.5-3 Mc/s) is calculated as follows:

$$\text{INJECTION FREQUENCY} = \text{SIGNAL FREQUENCY} \pm \text{1ST INTERMEDIATE FREQUENCY}$$

Either the fundamental crystal frequency or its 2nd or 3rd harmonic can be used to furnish the injection frequency so that high frequency operation is obtained with crystals of relatively low frequency.

If the receiver is to be operated with the 2nd Local Oscillator also crystal controlled, the frequency to be substituted in the formula for the 1st IF is equal to the 2nd Oscillator crystal frequency plus 100 kc/s. (refer to Table on previous page)

In most cases the 2nd Oscillator will not be locked with a crystal and this makes the choice of 1st Oscillator crystal much more flexible because the 1st IF can be set to any frequency in the range 1250-1450 kc/s by use of the INCREMENTAL TUNING CONTROL. The method of calculating all possible frequencies which the crystal could have to control a specific signal channel is illustrated in the example below:

EXAMPLE.

Determine the range of crystal frequencies which could be used to control a signal frequency of 7025 kc/s.

- (a) The signal channel is higher than 3 Mc/s so there is no restriction on which side the injection frequency must lie.
- (b) First determine the 'nominal' injection frequencies. These are the frequencies which will result in a 1st IF of 1350 kc/s, i.e. the nominal 1st IF.

Nominal injection frequencies in this case are:

$$7025 + 1350 = \underline{8375 \text{ kc/s}} \quad \text{and} \quad 7025 - 1350 = \underline{5675 \text{ kc/s.}}$$

- (c) The first IF coverage extends 100 kc/s to either side of the nominal value so that the injection frequency could lie anywhere in the range 100 kc/s above and below the nominal frequencies determined above.

The range of possible injection frequencies is therefore as follows:

$$(8375 - 100) \text{ to } (8375 + 100) = \underline{8275 \text{ to } 8475 \text{ kc/s.}} \quad (\text{Oscillator 'high'})$$

$$(5675 - 100) \text{ to } (5675 + 100) = \underline{5575 \text{ to } 5775 \text{ kc/s.}} \quad (\text{Oscillator 'low'})$$

- (d) Assume that a crystal is available for 8350 kc/s. This frequency falls within the 'high' range determined above and is 25 kc/s below the nominal value of 8375 kc/s.

Next, determine the incremental setting that will give an effective tune frequency of 7025 kc/s. The setting depends on the actual 1st IF and this is obtained from the formula:

$$\text{1ST INTERMEDIATE FREQUENCY} = \text{INJECTION FREQUENCY} - \text{SIGNAL FREQUENCY}$$

Substituting values:

$$\text{1st IF} = 8350 - 7025 = \underline{1325 \text{ kc/s.}}$$

Reference to the Table on the previous page gives the incremental setting as '25' in the RED sector of the scale.

NOTE All figures are applicable to the 830, 830/1 and the 830/2

(e) In the previous paragraph, operation has been considered with injection on the 'high' side of the signal. When a 'low' injection frequency is chosen, the procedure must be modified as follows:

The formula for determining the 1st IF becomes:

$$\text{1ST INTERMEDIATE FREQUENCY} = \text{SIGNAL FREQUENCY} - \text{INJECTION FREQUENCY}$$

Substituting values on the assumption that a crystal is available for a frequency of 5625 kc/s:

$$\text{1st IF} = 7025 - 5625 = \underline{1400 \text{ kc/s.}}$$

Reference to the Table gives an incremental setting of 50 BLACK and this reveals one important change which occurs when the 1st Oscillator is placed on the 'low' side of the signal.

In the previous case (with injection 'high') a crystal of frequency lower than the nominal injection frequency was used and the appropriate incremental setting lay in the RED sector. In the second example (injection 'low'), the crystal chosen was again lower than the nominal value but in this case the incremental setting fell in the BLACK sector.

It is most important that the reason for this is clearly understood and the reader is referred to the worked example which appears on page 7.

The incremental scale is calibrated on the assumption that the 1st Local Oscillator is on the high side of the signal with the result that if a low injection frequency is used then the RED portion of the scale which normally indicates a higher tune frequency actually indicates a lower frequency. The figures marked on the scale must also be reversed such that 90 must read 10, 60 must read 40, 30 must read 70 etc., etc. Any possible confusion will disappear after familiarisation on the equipment.

When the receiver is operated with 'Manual' control, any small error which may be present in the incremental calibration is automatically corrected when the 1st Local Oscillator is adjusted to correct the main scale calibration. With crystal control of the 1st Local Oscillator, this automatic correction is not available and it is therefore necessary to determine the incremental scale accuracy by reference to either of the two crystal check points which are available for this purpose. These occur at '50 RED' and '50 BLACK' and, as with calibration of the main scale, any check should be made at the nearest check point to the required setting.

Continuing one of the examples given previously - a setting of '25 RED' was called for and the calibration check would therefore be made at '50 RED'. To do this, bring the Calibrator into operation and tune to zero beat with the crystal harmonic. Note the incremental scale reading. Assuming in this case that this is say 51.5, then the incremental scale reading is 1.5 kc/s low and a positive correction must be applied to '25 RED' making it '26.5 RED'.

Note that this correction is unaffected by the position of the 1st Oscillator frequency (i.e. whether high or low).

As mentioned previously, detuning the 1st IF from its nominal frequency results in misalignment of the signal frequency circuits. With the 1st Oscillator crystal controlled, the necessary correction can be achieved either by use of the PEAK RF CONTROL or the MAIN TUNING CONTROL since the latter does not in this case have to be set to determine the oscillator frequency. This arrangement allows full correction at all frequencies in the range.

Crystals are installed in a holder assembly which is located at the rear of the front panel to the right of the main tuning gang when the receiver is viewed from the rear with the cover removed.

The eight holders are labelled 'A - B - C - etc.' to correspond with the markings of the CRYSTAL SELECTOR SWITCH and it is suggested that a small card is made up to indicate the signal frequency obtaining in each position of the switch. The card can be attached to the equipment for the convenience of the operator and can take the form outlined below:

Position	Signal Freq. kc/s	Incremental Setting	Crystal kc/s.
A	7025 kc/s	25 RED	8350 kc/s
B			
C etc.			

AM and CW Reception.

Tuning procedures for 'AM' and 'CW' reception are strictly conventional and call for little comment except perhaps to point out that the noise limiter is operative only in the 'AM' position of the SIGNAL MODE SWITCH. The type of detector used for CW/SSB reception has inherent pulse suppression properties and a separate limiter is required only for 'AM' reception. It follows therefore that with the SIGNAL MODE SWITCH at 'CW' (or 'SSB'), the combined AGC/NL SWITCH is effectively an 'AGC SWITCH' only, moving the control in either direction from the centre position having no effect other than bringing the AGC into operation.

SSB Reception.

Several useful features are incorporated in the 830 receiver to simplify the tuning procedure for 'SSB' reception. The SIGNAL MODE SWITCH for example has two 'SSB' positions to eliminate the need for initial 'coarse' adjustment of the carrier re-insertion frequency. Selecting either 'SSB' position (marked 'UPPER' and 'LOWER') automatically places the carrier frequency in approximately the right position relative to the centre frequency of the 2nd IF channel. 'Fine' adjustment of this initial setting is provided by the BFO PITCH ADJUSTOR which, although having a swing of ± 3 kc/s when the SIGNAL MODE SWITCH is at 'CW', has a much restricted swing of the order ± 100 c/s when either 'SSB' position is selected. This range of adjustment is spread over some 270° of control rotation so that precise adjustment presents no problem.

Before attempting to tune an 'SSB' signal, first make sure that the SELECTIVITY CONTROL is set to 'SSB'. A click-stop is provided to ensure that the correct bandwidth is selected accurately and once set the control should not be disturbed.

During the initial tuning adjustments, the RF and AF GAIN CONTROLS are fully advanced and adjustment of the signal level is by means of the IF GAIN. An adequate range of control adjustment will be found on all but extremely strong signals when the control range of the IF GAIN can be supplemented by adjustment of the RF GAIN. (Once the signal has been properly resolved, the IF GAIN should be fully advanced to secure maximum AGC action and control of the output will then be with the AF GAIN.)

Initial tuning of 'SSB' signals is most conveniently carried out with the SIGNAL MODE SWITCH in the 'AM' position since this permits using the built-in carrier level meter as an indication of correct tuning. This cannot be done at 'SSB' because the AGC discharge time constant is then increased considerably and the meter action is therefore extremely sluggish. In the 'AM' position where the AGC time constant is relatively fast, the meter indication is good except on the weaker signals. This is no real disadvantage because experience shows that weak signals can be tuned quite satisfactorily by ear.

The rapid fluctuation of the meter needle due to the speech or tone on the signal, and the unnatural sound of the 'garbled' output may cause some confusion at first but this will be rapidly overcome and the ability to tune signals with the required degree of accuracy will quickly develop.

The object is to tune the receiver so that the signal lies in the centre of the IF passband and so falls within the range of the BFO PITCH ADJUSTOR. Once this has been done, the SIGNAL MODE SWITCH is moved from the 'AM' position to 'SSB UPPER' and then to 'SSB LOWER'. Note the position which gives the greatest intelligibility and leave the switch in that position. (If the transmitted sideband is known beforehand, there will be no need to make this check and the switch can be set to the appropriate position straight away). Adjusting the BFO PITCH ADJUSTOR in its role as a 'fine' tuning control will now allow the signal to be completely resolved to give natural sounding speech.

Carrier Level Meter.

The built-in meter serves a dual purpose in that it can be used either as a tuning indicator or as a means of comparing the relative strength of received signals. A pre-set METER ZERO CONTROL is provided at the rear of the receiver and this should be set correctly before using the meter. To adjust this control, proceed as follows:

1. Bring the AGC into operation and set the RF and IF GAIN CONTROLS at maximum.
2. Disconnect the aerial feeder and terminate the aerial socket with a non-inductive 75Ω resistor.
3. Adjust the METER ZERO CONTROL so that the meter needle takes up a position coincident with the '0' mark at the left-hand side of the meter scale.
4. Re-connect the aerial feeder.

The meter reading will be affected by the RF and IF GAIN CONTROL settings and these should not be disturbed while making comparative checks. AGC must be operative to allow use of the meter and any random movement of the meter needle which may occur when the AGC is off should be disregarded since it is due entirely to overload of the receiver when tuned to the stronger signals.

MAINTENANCE

GENERAL

The Model 830 receiver is suitable for continuous operation in all areas under extreme climatic conditions and should require very little in the way of maintenance over long periods of use. Normal routine maintenance schedules can be drawn up but these should be restricted to such things as 'cleaning the exterior', 'checking the serviceability of external connections', 'checking that full error correction is possible by use of the cursor adjustor', etc.

The geared drive systems and other mechanical arrangements will not normally require attention because initial lubrication during manufacture is carried out with a permanent lubricant (molybdenum disulphide). If additional lubrication should become necessary after the equipment has been in use for a prolonged period of time, this can be carried out with any light mineral oil suitable for the temperature conditions under which the receiver is operated. The lubricant should be applied very sparingly.

NOTE Receivers can be returned to the Manufacturer for advanced servicing should this become necessary.

Dial Lamp Replacement.

Faulty dial bulbs can be changed quite simply after removal of the cabinet. To free a holder from the support strip, merely squeeze its two sides together and pull away from the strip. The bulbs are standard bayonet types with a rating of 6.5V @ 0.3A.

Fuse Replacement.

The two mains fuses are located at the rear of the receiver and are readily accessible for replacement in the event of failure. Replacement fuses should be rated at 2 Amps and are standard miniature cartridge types with outside dimensions 20mm x 5mm.

In the case of the 830/2 and 830/3, only one fuse is fitted. This has a rating of 1.5 Amps and is a $1\frac{1}{2}$ " x $\frac{1}{4}$ " thermal storage delay type.

Valve Replacement.

All valves except two are immediately accessible for replacement on removal of the cabinet. The majority are fitted with screening cans and care should be taken to replace these after fitting a new valve. The two valves that are not accessible are V3 and V4 which are located in the screened box at the right-hand side of the receiver. The top cover of this box can be removed by taking out the four retaining screws. Both valves are held in place with spring retainers and these must be replaced whenever a new valve is fitted.

Standard CV valve types are used throughout and no difficulty should be experienced in obtaining replacements. Direct equivalents can be used where necessary and any valve can be changed without necessitating re-alignment of the tuned circuits.

Cursor Drive Wire Replacement.

In the unlikely event of the drive wire either breaking or slipping out of the pulley grooves, replacement will be much simplified (even when the wire is undamaged) if a new length is obtained. This can be made longer than the length actually required (this being approximately 4') and will therefore be easier to handle. Fitting a new wire is quite straightforward and will present no difficulties if the instructions given below are followed carefully step by step.

NOTE In these instructions, left-hand and right-hand are as viewed from the rear of the receiver.

1. Take off the cabinet.
2. Remove the old drive wire by slackening the 6BA screws in the two drive pulleys and unsoldering from the cursor carrier.
3. Rotate the cursor adjustor in an anti-clockwise direction until its end-stop is reached. This corresponds to maximum cursor movement towards the high frequency end of the scale and the adjustor should be left at this setting.
4. Rotate the main tuning control in an anti-clockwise direction until the tuning gang is fully meshed.
5. Attach one end of the new drive wire to the 6BA screw in the left-hand drive pulley. (The screw should be at approximately 2 o'clock.)
6. Feed the wire through the pulley slot and into the groove nearest to the panel so that it leaves the pulley from right to left.
7. Pass wire round jockey pulley and across main dial between cursor guide rods, passing under cursor carrier.
8. Hold the free end of the wire and rotate the main tuning control in a clockwise direction so that three complete turns are wound onto the left-hand drive pulley. The

wire must be held in tension while winding and rotation of the tuning control should continue until the gang is fully meshed.

9. Pass the wire clockwise over the right-hand guide pulley and then downwards and under the cursor shift pulley. Maintain tension to prevent wire slipping off drive pulley.
10. Run the wire under the meter and across towards the right-hand drive pulley.
11. Lay the wire in the second groove from the edge of the pulley which is nearest to the rear of the receiver. Feed the wire along the groove and through the pulley slot which should lie at about 10 o'clock.
12. Apply sufficient tension to the free end of the wire to cause the jockey pulley to take up a position roughly $\frac{1}{8}$ " from the cursor guide rod support bracket. Secure the wire to the 5BA screw and cut off the surplus wire.
13. Slide the cursor carrier along the guide rod to the high frequency end of the scale. Set the cursor adjustor to mid-travel and then carefully line up the cursor with the extreme ends of the horizontal scale lines. Solder the cursor carrier to the drive wire.
14. Check the drive for free and normal operation and rotate the cursor adjustor to check that it provides an independent lateral movement of just under $\frac{1}{4}$ ".
15. Check the scale accuracy against the internal crystal calibrator.

Cleaning the Scale and Scale Window.

1. Take off the cabinet.
2. Remove the small side castings at the extremities of the glass window. These are held in place by hexagon headed screws which are accessible through small rectangular cut-outs near the leading edge of the side plates. The screws are captive and a standard 4BA spanner is required for removal.
3. Remove the three dial lamp holders from their support strip. These are clipped into position and are easily disengaged from the fixing slots by squeezing together the two sides of the holder.
4. Take out the four countersunk screws along the top edge of the panel and remove the long dial lamp strip.
5. This strip also serves to support the top edge of the dial glass which can now be removed by lifting up and tilting back slightly.
6. The dial glass can be cleaned with one of the many domestic products which are available for this purpose. The scale can be cleaned if necessary by rubbing gently with a soft lint-free cloth which has been moistened slightly in warm water. Any surplus moisture should be removed with a dry cloth before replacing the dial glass.

RE-ALIGNMENT

General.

In the unlikely event of a complete re-alignment being required, the instructions given on the following pages should be followed step by step in full. In the more usual case of partial re-alignment required to compensate for ageing components etc., the relevant instructions can be extracted as required. It must be stressed that alignment adjustments should not be tampered with unless there is a clear indication that alignment is in fact required, and furthermore adjustments should only be carried out by fully skilled technicians equipped with suitable test instruments.

NOTE All dust cores are self-locking (rubber string and silicone core-retaining compound) so that there is no need to use wax etc. for sealing purposes. The concentric trimmers are also self-locking.

Re-alignment of the 100 kc/s IF Amplifiers and the Crystal Filter.

Test Equipment Standard Signal Generator covering the IF of 100 kc/s. Output impedance in the range 10-75Ω and with provision for modulation at 400 c/s.

Valve Voltmeter (f.s.d. 1V).

Output Meter matched to 2.5/3Ω.

Trimming Tools. (1) Insulated screwdriver. (2) Neosid H.S.1.
(3) Small Tommy bar (5/64" diameter).

Switch on the receiver, signal generator and valve voltmeter and allow half an hour to reach operating temperature. Set the receiver controls as follows:-

WAVECHANGE	. . .	Range 9.	IF GAIN	. . .	Maximum.
SELECTIVITY	. . .	'N' (Crystal).	AGC/NL	. . .	Off.
MODE	. . .	'AM'.	CRYSTAL		
			SELECTOR	. . .	To any vacant 'crystal' posn.

Check that a shorting link is in position between PL4/1 and PL4/4.

Remove the gang cover (complete with Calibrator Unit) and connect the output lead from the signal generator to the stator of the Mixer section (C58) of the main tuning gang. The valve voltmeter should be connected to the IF Output socket (SKT2). If a valve voltmeter is not available, the built-in carrier level meter can be used (AGC must then be 'ON') but the indication obtained will be inferior to that obtained with the instrument specified.

When the equipment has reached operating temperature, set the signal generator (with unmodulated output) to approximately 100 kc/s and tune slowly across the IF pass-band. At the point where the generator output frequency coincides with that of the filter crystal, a sharp rise in output reading will be obtained. The generator should be set accurately to this peak and the attenuator adjusted to give an output reading of approximately 500mV as indicated by the valve voltmeter. (Note. SKT2 is unterminated.)

Now proceed to trim the cores in T1, T2, T3 and T4. The top cores (T1, T3 and T4) tune the secondary windings of these transformers and all cores are set to their 'outer' peak, i.e. the one that occurs when the core is furthest from the opposite coil. The generator output should be reduced as necessary to keep the output reading below 500mV.

Once the transformers have been accurately aligned to the centre-frequency, increase the output from the generator and detune it by equal amounts above and below the centre-frequency to determine by observation of the output reading whether the response is symmetrical or not. Any loss of symmetry is likely to be slight and it is doubtful whether the rejection notch due to the filter crystal would be visible. If the response is asymmetrical it can easily be corrected by slight re-adjustment of the pre-set crystal phasing capacitor C88. This is accessible on the side of T2 nearest to the central RF Section and can be adjusted with a 'small tommy bar slipped into one of the holes in the spindle extension that protrudes from the side of the can.

In making this adjustment, the initial setting of C88 should be changed slightly first in one direction and then in the other to determine which gives an improvement in the response. Once the direction is known, C88 should be adjusted by small increments until a symmetrical response is obtained. Care should be taken not to over-correct since this will result in the response becoming tilted in the opposite direction and if carried far enough will introduce the rejection notch due to the crystal.

On completion of these adjustments, set the Selectivity Control to 'AM' and tune the generator slowly through the IF passband to determine whether the nose of the response is reasonably flat. If it is found to be a little assymmetrical, re-adjust T2 slightly to give a flatter response. The change in core position will be very small and will not affect the response in the other selectivity positions.

This completes the alignment of the 100 kc/s Amplifiers and it is convenient at this stage to make a check on the 2nd IF sensitivity. The generator should be connected as before but with its output modulated to a depth of 30% at 400 c/s. If an external loudspeaker has been connected this should be removed and the output meter (matched to 2.5/3Ω) wired in its place, i.e. to PL4/7 and PL4/9. Set the Selectivity Control to the 'CW' position and the AF Gain to maximum and then tune the generator for maximum reading on the meter, adjusting the output to 50mW by means of the attenuator. A sensitivity of the order 6μV should be obtained.

Should the sensitivity appear low, stage by stage checks can be made with the generator applied directly to the grid of each IF Stage in turn. The grid connection in each case is pin 1 and the following approximate sensitivities can be expected with the Selectivity Control in the 'CW' position.

Generator applied at grid of V5	100μV for 50mW output.
Generator applied at grid of V6	8mV for 50mW output.

If after changing valves, making voltage checks etc., the sensitivity is still low from the grid of V6, make a check on the AF sensitivity. At 1000 c/s with an audio generator connected directly across the AF Gain Control (RV4) this should give a figure of the order 28mV for 50mW output.

Re-alignment of the BFO.

Test Equipment	Signal Generator covering the IF of 100 kc/s with an attenuator calibrated directly in dB.
.....	Valve Voltmeter (f.s.d. 1V).
	Trimming Tools. (1) Neosid H.S.1. (2) Screwdriver.

The signal generator and valve voltmeter are connected and the receiver controls adjusted exactly as specified initially in the notes on IF alignment. Allow half an hour for the equipment to reach operating temperature.

Tune the generator accurately to the crystal peak using the valve voltmeter as an indication of correct tuning. Set the BFO Pitch Adjustor so that the white index on the control knob is at 12 o'clock. (Note. This setting does not coincide with the potentiometer mid-travel position. To obtain greater linearity over the control swing the index is set coincident with the right-hand panel marking when the potentiometer is fully clockwise. The accuracy of this adjustment should be verified before proceeding). Move the Mode Switch to 'CW' and adjust L37 so that the BFO signal is zero-beat with the generator. Check that the Pitch Adjustor operates normally and then re-set the knob at 12 o'clock.

Now move the Selectivity Control to 'SSB' and adjust the generator output so that a reference reading of say 250mV is obtained on the valve voltmeter. Increase the output from the generator by 10dB and detune it above 100 kc/s until the valve voltmeter again registers 250mV. With the generator set to this frequency, move the Mode Switch to 'SSB UPPER' and adjust RV6 (marked 'USB') to obtain zero-beat. Retune the generator to the low side of 100 kc/s, adjusting as before for an output reading of 250mV and set RV7 ('LSB') for zero-beat with the Mode Switch at 'SSB LOWER'.

Finally, check that in both 'SSB' positions, the BFO Pitch Adjustor gives a swing of approximately ± 100 c/s.

Re-alignment of the 2nd Mixer Unit.

Test Equipment Standard Signal Generator modulated 30% at 400 c/s having an output impedance in the range 10-75 Ω and covering the frequency band 1250-1450 kc/s.

Crystal controlled harmonic generator providing 100 kc/s and 10 kc/s marker signals in the band 1250-1450 kc/s.

Output Meter matched to 2.5/3 Ω .

Trimming Tools. (Neosid H.S.1. and Mullard TCT01.).

First check the accuracy of the incremental scale calibration by feeding the output of the harmonic generator to the grid of the 1st Mixer Stage (i.e. to the stator of the Mixer section of the main tuning gang). The receiver controls should be set as indicated below and a period of at least half an hour should be allowed for the equipment to reach normal operating temperature.

WAVECHANGE	. . . Range 6.	BFO PITCH	. . . Index at 12 o'clock.
SELECTIVITY	. . . 'CW'.	AGC/NL	. . . Off.
MODE	. . . 'CW'	CRYSTAL	
IF/AF GAINS	. . . Adjust as necessary to provide suitable o/p.	SELECTOR	. . . To any vacant crystal position.

With the harmonic generator arranged to provide 100 kc/s markers, tune in turn to the two 50 kc/s calibration points on the incremental scale. These correspond to 1st intermediate frequencies of 1300 kc/s in the red sector and 1400 kc/s in the black sector. Determine what error (if any) exists and then introduce the 10 kc/s markers to check the accuracy at the centre and the extreme ends of the range. If on completion of this check the scale is found to be accurate to within one kilocycle, re-alignment of the 2nd Oscillator will not be required: if otherwise, proceed as follows.

Remove the cover plate from the side of the 2nd Mixer Unit to reveal the alignment plate which is retained underneath it. The alignment plate has holes to allow access to L36 and C65 and should be replaced using two of the screws just removed to hold it temporarily in position while adjustments are carried out.

The alignment points to be used are 10 kc/s in from the extreme ends of the incremental range and will be referred to as the 'red alignment point' and the 'black alignment point'. The frequencies which correspond to these settings are 1260 kc/s and 1440 kc/s respectively, and the generator is therefore arranged to provide 10 kc/s markers.

Set the incremental scale to the 'black alignment point' and tune to zero-beat with the marker signal at 1440 kc/s by adjustment of the concentric trimmer C65. Now tune to the 'red alignment point' and adjust the core in L36 for zero-beat against the marker on 1260 kc/s. Return to the 'black alignment point', repeat the adjustment of C65 and then make alternate adjustments to L36 and C65 until both alignment points are correct.

Now check each of the 10 kc/s points throughout the range of the incremental scale to determine the overall accuracy. If any point should be in error by more than one kilocycle, the rotor vanes of C64 can be adjusted to effect a correction but it is extremely unlikely that this treatment would be required.

On completion of the adjustments just described, disconnect the harmonic generator and connect the signal generator in its place preparatory to alignment of the tunable IF transformer L34/L35. An output meter should be wired to PL4/7 and PL4/9 and the top cover must be removed from the 2nd Mixer Unit to allow access to the trimmers C74 and C77 which are mounted on the tuning gang. The receiver control settings should be adjusted as indicated on the following page.

SIGNAL MODE SWITCH	. . .	'AM'.	AF GAIN CONTROL	. . .	To any convenient level but to maximum when checking sensitivity.
SELECTIVITY CONTROL	. . .	'CW'.			
IF GAIN CONTROL	. . .	Maximum.			

Tune the generator to 1440 kc/s (modulation 30% at 400 c/s and attenuator at approximately 10 μ V setting) and set the incremental scale to the 'black alignment point'. Adjust C74/C77 for maximum output and then retune the generator to 1260 kc/s. Set the incremental scale at the 'red alignment point' and trim the cores in L34/L35. Repeat these adjustments as necessary until correct alignment is obtained.

A check on the sensitivity (generator at 1350 kc/s, incremental scale to centre-zero) should give a figure of the order 1 μ V for an output of 50mW with the speaker disconnected.

Re-alignment of the RF Section.

Test Equipment	Standard Signal Generator modulated 30% at 400 c/s with an output impedance matched to 75 Ω covering the frequencies 300 kc/s - 30 Mc/s.
.....	Crystal controlled harmonic generator providing 1 Mc/s markers up to 30 Mc/s.
	Output Meter matched to 2.5/3 Ω .
	Trimming Tools. (1) Neosid H.S.1. (2) Mullard TCT01. (3) Insulated screwdriver.

The first step in this part of the alignment procedure is to check the accuracy of the scale calibration to determine whether re-alignment of the 1st Local Oscillator will be required. This operation can be carried out by using the built-in 100 kc/s crystal calibrator in conjunction with an external generator giving 1 Mc/s markers. The latter will be found invaluable on the higher frequency ranges (especially Ranges 1 and 2) where there may be some uncertainty as to which 100 kc/s markers fall on the megacycle points. The external calibrator can be conveniently introduced at the aerial socket and the receiver controls should be set as indicated below:

SIGNAL MODE SWITCH	'AM' while using internal calibrator but to 'CW' when the external calibrator is in use.
RF/IF/AF GAIN CONTROLS	Adjust as necessary to provide a suitable output.
SELECTIVITY CONTROL	'CW'.
INCREMENTAL TUNING	Set to '0' mark at centre of range.
CRYSTAL SELECTOR	'M' (Manual).
PEAK RF CONTROL	Index at 12 o'clock.
CALIBRATOR SWITCH	'ON' (except when using 1 Mc/s markers).
CURSOR ADJUSTOR	Mid-travel.
AGC/NL	'OFF'.

NOTE All equipment should be allowed at least half an hours warm-up period and both calibrators should be standardised against a standard frequency transmission before commencing the calibration check.

To prove the scale accuracy, select each range in turn and determine whether or not the correction afforded by the cursor adjustor is sufficient to compensate for any error that may be present. Checks should be made at each 100 kc/s point on Ranges 4-9 and at 1 Mc/s intervals on the other ranges. If alignment is found to be necessary, this should be restricted to the range or ranges which is/are in error. Alignment adjustments should be made at the frequencies listed in the Table on the following page. Standard tracking procedure applies, i.e. adjust trimmers at HF end and cores at LF end. All dust cores are slotted types and should be adjusted with an insulated screwdriver.

NOTE Alignment of the RF Section must be carried out with the coil box cover in place.

Range	Trimming Freq.	Trimmer	Padding Freq.	Core
1	30.0 Mc/s	C128	18.0 Mc/s	L25
2	18.0 Mc/s	C129	11.2 Mc/s	L26
3	10.8 Mc/s	C130	6.8 Mc/s	L27
4	6.6 Mc/s	C131	4.1 Mc/s	L28
5	4.0 Mc/s	C132	2.55 Mc/s	L29
6	2.45 Mc/s	C133	1.55 Mc/s	L30
7	1480 kc/s	C134	870 kc/s	L31
8	830 kc/s	C135	490 kc/s	L32
9	500 kc/s	C136	300 kc/s	L33

After the scale calibration has been checked and any necessary adjustments have been made to the 1st Oscillator circuits, alignment of the signal frequency circuits can be commenced. Connect the signal generator in place of the 1 Mc/s calibrator and wire the output meter across PL4/7 and PL4/9. The loudspeaker can remain connected as an aural monitor during alignment but must be disconnected when making sensitivity checks. Arrange the generator output impedance to match the receiver input (75Ω), set the modulation to 30% at 400 c/s and then adjust the receiver controls as follows:

RF AND IF GAIN CONTROLS	Maximum.
AF GAIN CONTROL	Any convenient level (max. during sens. check)
SIGNAL MODE SWITCH	'AM'.
INCREMENTAL TUNING	Set to '0' mark at centre of range.
SELECTIVITY CONTROL	'SSB'.
CRYSTAL SELECTOR SWITCH	'M' (Manual).
AGC/NL SWITCH	Off.
PEAK RF CONTROL	Index at 12 o'clock. (Check that this corresponds to the half-capacity setting of the 'peak RF' capacitors.)

Alignment adjustments should be made at the frequencies given in the Table below, each adjustment being repeated at least twice to ensure accurate alignment. On completion of the adjustments on each range, make a check on the sensitivity at the mid-band frequency. Remember that the Selectivity must be at 'SSB' for this check which should give figures of the order 3μV or less for an output of 50mW with a s/n ratio of 15dB.

Range	Trimmers				Cores			
	Freq.	Aerial	RF	Mixer	Freq.	Aerial	RF	Mixer
1	30.0 Mc/s	C9	C15	C42	18.0 Mc/s	L1	L7	L16
2	18.0 Mc/s	C10	C16	C43	11.2 Mc/s	L2	L8	L17
3	10.8 Mc/s	C11	C17	C44	6.8 Mc/s	L3	L9	L18
4	6.6 Mc/s	C12	C18	C45	4.1 Mc/s	L4	L10	L19
5	4.0 Mc/s	C13	C19	C46	2.55 Mc/s	L5	L11	L20
6	2.45 Mc/s	C14	C20	C47	1.55 Mc/s	L6	L12	L21
7	1480 kc/s	C21	-	C48	870 kc/s	L13	-	L22
8	830 kc/s	C22	-	C49	490 kc/s	L14	-	L23
9	500 kc/s	C23	-	C50	300 kc/s	L15	-	L24

APPENDIX 'A'

MODEL 830/1

This version of the standard model differs only in the type of knobs used for the 'SELECTIVITY CONTROL', the 'SIGNAL MODE SWITCH' and the 'AGC/NL SWITCH'. Small 'beak' knobs are fitted in place of the standard chromium plated levers.

MODEL 830/2

The Model 830/2 is the general production version of the '830' from which it differs in the following respects.

Mains Connector.

A non-reversible mains connector is used in lieu of the reversible type fitted on the standard model. Coding of the lead attached to the connector is as follows:

RED : Live. BLACK : Neutral. GREEN : Earth.

Fuse.

A single fuse is fitted in place of the two fuses found on the standard '830'. A 1 $\frac{1}{4}$ " cartridge type (thermal storage delay type rated at 1.5A) should be used for replacement in the case of the 830/2.

Cabinet Fixing Screws.

Standard 2BA screws are used in place of the captive type used on the 830 & 830/1.

Incremental Scale.

On the 830/2, the method of presenting the calibration on the incremental scale differs from that used on the standard 830 and 830/1. The difference is restricted to the 'black' portion of the scale and can be seen clearly by comparing the 830/2 calibration which is given below with that of the standard model which appears on page 21. In both cases, the figures that are underlined are those which appear in RED.

100 - 90 - 80 20 - 10 - 0 - 10 - 20 - 30 80 - 90 - 100

The effective tune frequency is obtained by taking the incremental reading and adding it to, or subtracting it from the reading on the main scale. The reading is added if it appears in red, subtracted if in black.

This rule should always be followed except in the case of the 1st Local Oscillator providing an injection frequency on the low side of the signal when crystal controlled. In this case, the red reading indicates a lower frequency and the black reading a higher frequency. Thus in this case only, red readings are subtracted and black ones added.

NOTE In the text of the Manual, certain paragraphs which refer to the incremental tuning are applicable only to the 830 and 830/1. These are indicated by a vertical line at the left-hand side of the text and should be ignored by 830/2 users. All explanatory calculations have been carried out with figures which are common to both types of scale.

MODEL 830/3

This version is a variant of the 830/2, the only difference being the type of knob used for the RF Gain control. References in the text to the 830/2 receiver can be taken to include the 830/3.

APPENDIX 'B'

TABLE OF VOLTAGE VALUES

The following 'Table of Voltage Values' will prove useful in the event of the receiver developing a fault which necessitates carrying out voltage checks. All readings are typical and were taken with a meter having a sensitivity of 20,000Ω/V and an applied mains voltage of 240V. A nominal tolerance of 10% will apply to readings taken with a meter of the sensitivity quoted and this tolerance should be increased accordingly if readings are taken with a meter of lower sensitivity.

Readings should be taken under 'no-signal' conditions with the receiver controls set as follows:-

WAVECHANGE	Range 1.	RF/IF GAIN CONTROLS	Maximum.
CRYSTAL SELECTOR	'M' (Manual).	AF GAIN CONTROL	Minimum.
SIGNAL MODE SWITCH	'CW'.	AGC/NL SWITCH	Off.

The link between PL4/1 and PL4/4 must be in position.

Ref	Anode		Screen		Cathode		Note	
	Pin	Reading	Pin	Reading	Pin	Reading		
V1A	6	90V	-	-	8	1.5V	NOTE 1.	
V1B	1	178V	2 (g1)	87V	3	90V		
V2	5	186V	6	40V	2	0.7V		
V3	1	90V	-	-	7	0V		
V4	5	185V	6	25V	2	0.45V		
V5	5	220V	6	95V	7	1.1V		NOTE 2.
V6	5	220V	6	95V	7	1.1V		
V7	2/7	10V	-	-	1/5	10V		
V8	5	188V	6	188V	7	2.2V		
V9	7	110V	-	-	2	13V		NOTE 3.
V10	5	230V	6	227V	2	12V		
V11	5	30V	6	160V	7	0V		NOTE 4.
V12A	6	128V	3	112V	7	0V		
V12B	1	96V	-	-	8	1.2V		NOTE 5.
V13	-	-	-	-	-	-		NOTE 6.
V14	1	150V	-	-	7	0V		
V15	1	150V	-	-	7	0V		

NOTE 1. Cathode voltage increases to 46V with RF GAIN at minimum.

NOTE 2. Cathode voltage increases to 45V with IF GAIN at minimum.

NOTE 3. Cathode voltage decreases to 4.9V when the SIGNAL MODE SWITCH is moved to 'SSB'.

- NOTE 4. CALIBRATOR SWITCH to 'ON' position. The Calibrator Unit must be removed from the gang cover to allow readings to be taken.
- NOTE 5. CRYSTAL SELECTOR SWITCH to any 'CRYSTAL' position and with crystal in place.
- NOTE 6. This stage is inaccessible for direct voltage checks. Voltages can be checked on the leads entering the unit as follows:
- (a) Anode feed (measured at orange lead) : 226V (CW/SSB), 231V (AM).
 - (b) Screen feed (measured at blue lead) : 138V.
 - (c) Diode control voltage (measured at green lead). Reading depends on the position of the SIGNAL MODE SWITCH.
 - 'AM' position 0V.
 - 'CW' position 10.5V to 19V for full swing of the BFO PITCH ADJUSTOR. (Nominally 14.5V at centre setting).
 - 'SSB UPPER' In the range 12V to 24V (nominal).
 - 'SSB LOWER' In the range 8V to 20V (nominal).

HT voltages are as follows:-

HT1 . . . 238V. HT3 and HT4 . . . 150V.
 HT2 . . . 226V (MODE SWITCH to 'CW')

APPENDIX 'C'

LIST OF COMPONENT VALUES, TOLERANCES AND RATINGS

Capacitors.

Ref	Value	Type	Tolerance	Wkg. V.
C1	5-50pF	Air-spaced variable	-	-
C2	12-230pF	Air-spaced variable	-	-
C3	60pF	Silvered Mica	10%	350V
C4	60pF	Silvered Mica	10%	350V
C5	50pF	Silvered Mica	10%	350V
C6	25pF	Silvered Mica	10%	350V
C7	50pF	Silvered Mica	10%	350V
C8	10pF	Silvered Mica	10%	350V
C8a	0.0047μF	Polystyrene	5%	125V
C9	4-29pF	Air Trimmer	-	-
C10	4-29pF	Air Trimmer	-	-
C11	4-29pF	Air Trimmer	-	-
C12	4-29pF	Air Trimmer	-	-
C13	4-29pF	Air Trimmer	-	-
C14	4-29pF	Air Trimmer	-	-
C15	4-29pF	Air Trimmer	-	-
C16	4-29pF	Air Trimmer	-	-
C17	4-29pF	Air Trimmer	-	-
C18	4-29pF	Air Trimmer	-	-
C19	4-29pF	Air Trimmer	-	-

Ref	Value	Type	Tolerance	Wkg. V.
C20	4-29pF	Air Trimmer	-	-
C21	4-29pF	Air Trimmer	-	-
C22	4-29pF	Air Trimmer	-	-
C23	4-29pF	Air Trimmer	-	-
C24	50pF	Silvered Mica	10%	350V
C25	50pF	Silvered Mica	10%	350V
C26	40pF	Silvered Mica	10%	350V
C27	25pF	Silvered Mica	10%	350V
C28	30pF	Silvered Mica	10%	350V
*C29	10pF	Silvered Mica	10%	350V
C30	5-50pF	Air-spaced variable	-	-
C31	12-230pF	Air-spaced variable	-	-
C32	100pF	Silvered Mica	10%	350V
C33	0.1μF	Plate Ceramic	+80% -20%	200V
C34	0.1μF	Plate Ceramic	+80% -20%	200V
C34a	0.003μF	Metallised Paper	20%	350V
C35	0.047μF	Polyester	10%	400V
C36	25pF	Tubular Ceramic N750	10%	750V
C37	6pF	Tubular Ceramic N750	10%	750V
C38	6pF	Tubular Ceramic N750	10%	750V
C39	1pF	Tubular Ceramic N750	0.5pF	750V
C40	6pF	Tubular Ceramic N750	10%	750V
C41	500pF 800pF	Metallised Paper Silvered Mica	10%	600V 350V
C42	4-29pF	Air Trimmer	-	-
C43	4-29pF	Air Trimmer	-	-
C44	4-29pF	Air Trimmer	-	-
C45	4-29pF	Air Trimmer	-	-
C46	4-29pF	Air Trimmer	-	-
C47	4-29pF	Air Trimmer	-	-
C48	4-29pF	Air Trimmer	-	-
C49	4-29pF	Air Trimmer	-	-
C50	4-29pF	Air Trimmer	-	-
C51	40pF	Silvered Mica	10%	350V
C52	40pF	Silvered Mica	10%	350V
C53	40pF	Silvered Mica	10%	350V
C54	25pF	Silvered Mica	10%	350V
C55	40pF	Silvered Mica	10%	350V
C56	10pF	Silvered Mica	10%	350V
C57	0.0051μF	Polystyrene	5%	125V
C58	12-230pF	Air-spaced variable	-	-
C59	5-50pF	Air-spaced variable	-	-
C60	100pF	Silvered Mica	10%	350V
C61	0.047μF	Polyester	10%	400V
C61a	0.001μF	Tubular Ceramic	+50% -25%	750V
C62	0.1μF	Plate Ceramic	+80% -20%	200V
C63	0.047μF	Polyester	10%	400V
C64	7-43pF	Air-spaced variable	-	-
C65	4-29pF	Air Trimmer	-	-
C66	20pF	Silvered Mica	10%	350V
C67	20pF	Tubular Ceramic N750	10%	750V
C68	100pF	Silvered Mica	10%	350V
C69	0.01μF	Metallised Paper	20%	150V

* Fitted on early models only.

C63a . 100pF

Tubular Ceramic

10%

750V

Ref	Value	Type	Tolerance	Wkg. V.
C70	100pF	Silvered Mica	10%	350V
C71	0.01 μ F	Metallised Paper	20%	150V
C72	1500pF	Tubular Ceramic Feed Through	20%	500V
C73	7-43pF	Air-spaced variable	-	-
C74	4-29pF	Air Trimmer	-	-
C75	25pF 1SpF	Silvered Mica	10%	350V
C76	40pF	Silvered Mica	10%	350V
C77	4-29pF	Air Trimmer	-	-
C78	7-43pF	Air-spaced variable	-	-
C79	1500pF	Tubular Ceramic Feed Through	20%	500V
C80	1500pF	Tubular Ceramic Feed Through	20%	500V
C81	0.01 μ F	Metallised Paper	20%	150V
C82	100pF	Silvered Mica	10%	350V
C83	0.047 μ F	Polyester	10%	400V
C84	1500pF	Tubular Ceramic Feed Through	20%	500V
C85	0.002 μ F	Polystyrene	5%	125V
C86	0.0047 μ F	Polystyrene	5%	125V
C87	0.0047 μ F	Polystyrene	5%	125V
C88	2-10pF	Air Trimmer	-	-
C89	50pF	Silvered Mica	5%	350V
C90	0.002 μ F	Polystyrene	5%	125V
C91	100pF	Silvered Mica	10%	350V
C92	0.1 μ F	Plate Ceramic	+80% -20%	200V
C93	0.047 μ F	Polyester	10%	400V
C94	0.002 μ F	Polystyrene	5%	125V
C95	0.047 μ F	Polyester	10%	400V
C96	0.002 μ F	Polystyrene	5%	125V
C97	100pF	Silvered Mica	10%	350V
C98	0.047 μ F	Polyester	10%	400V
C99	0.047 μ F	Polyester	10%	400V
C100	0.002 μ F	Polystyrene	5%	125V
C101	0.047 μ F	Polyester	10%	400V
C102	12pF	Tubular Ceramic N750	10%	750V
C103	0.002 μ F	Polystyrene	5%	125V
C104	500pF	Metallised Paper	20%	600V
C105	10pF	Tubular Ceramic N750	10%	750V
C106	0.1 μ F	Plate Ceramic	+80% -20%	200V
C107	6pF	Tubular Ceramic N750	10%	750V
C108	50pF	Tubular Ceramic N750	10%	750V
C109	0.047 μ F	Polyester	10%	400V
C110	0.04 μ F	Tubular Paper	20%	250V
C111	500pF	Metallised Paper	20%	600V
C112	0.01 μ F	Tubular Ceramic	20%	500V
C113	0.005 μ F	Tubular Ceramic	10%	750V
C114	10 μ F	Tubular Electrolytic	+100% -20%	12V
C115	25 μ F	Tubular Electrolytic	+100% -20%	25V
C116	10 μ F	Tantalum	20%	25V
C117	0.1 μ F	Plate Ceramic	+80% -20%	200V
C118	50pF	Tubular Ceramic N750	10%	750V
C119	100pF	Tubular Ceramic N750	10%	750V

Ref	Value	Type	Tolerance	Wkg. V.
C120	0.01 μ F	Tubular Ceramic	20%	500V
C121	0.005 μ F	Disc Ceramic	+80%-20%	750V
C122	0.01 μ F	Tubular Ceramic	20%	500V
C123	25 μ F	Tubular Electrolytic	+100% -20%	25V
C124	0.01 μ F	Tubular Paper	20%	350V
C125	20pF	Silvered Mica	10%	350V
C126	6pF	Tubular Ceramic N750	10%	750V
C127	3-25pF	Air Trimmer	-	-
C128	4-29pF	Air Trimmer	-	-
C129	4-29pF	Air Trimmer	-	-
C130	4-29pF	Air Trimmer	-	-
C131	4-29pF	Air Trimmer	-	-
C132	4-29pF	Air Trimmer	-	-
C133	4-29pF	Air Trimmer	-	-
C134	4-29pF	Air Trimmer	-	-
C135	4-29pF	Air Trimmer	-	-
C136	4-29pF	Air Trimmer	-	-
C137	25pF	Tubular Ceramic N750	10%	750V
C138	25pF	Silvered Mica	10%	350V
C139	6pF	Tubular Ceramic N750	10%	750V
C140	20pF 40pF	Tubular Ceramic N750	10%	750V
C141	12pF	Tubular Ceramic N750	10%	750V
C142	50pF	Silvered Mica	10%	350V
C143	60pF	Silvered Mica	10%	350V
C144	60pF	Silvered Mica	10%	350V
C145	80pF	Silvered Mica	10%	350V
C146	20pF	Silvered Mica	10%	350V
C147	20pF	Silvered Mica	10%	350V
C148	25pF	Silvered Mica	10%	350V
C149	2350pF	Silvered Mica	1%	350V
C150	2000pF	Silvered Mica	1%	350V
C151	2300pF	Silvered Mica	1%	350V
C152	1425pF	Silvered Mica	1%	350V
C153	850pF	Silvered Mica	1%	350V
C154	570pF	Silvered Mica	1%	350V
C155	2825pF	Silvered Mica	1%	350V
C156	2000pF	Silvered Mica	1%	350V
C157	1200pF	Silvered Mica	1%	350V
C158	12pF (nom.)	Tubular Ceramic N750	10%	750V
C159	12-230pF	Air-spaced variable	-	-
C160	100pF	Tubular Ceramic N750	10%	750V
C161	100pF	Tubular Ceramic N750	10%	750V
C162	0.01 μ F	Metallised Paper	20%	150V
C163	0.01 μ F	Metallised Paper	20%	150V
C164	0.01 μ F	Metallised Paper	20%	150V
C165	500pf	Metallised Paper	20%	600V
C166	20pF	Tubular Ceramic N750	10%	750V
C167	20pF	Tubular Ceramic N750	10%	750V
C168	1500pF	Tubular Ceramic	20%	750V
C169	0.01 μ F	Metallised Paper	20%	150V

Ref	Value	Type	Tolerance	Wkg. V.
C170	50pF	Tubular Ceramic N750	10%	750V
C171	0.047 μ F	Polyester	10%	400V
C172	0.1 μ F	Plate Ceramic	+80% -20%	200V
C173	50pF	Silvered Mica	10%	350V
C174	25 μ F	Tubular Electrolytic	+100% -20%	25V
C175	500pF	Metallised Paper	20%	600V
C176	500pF	Metallised Paper	20%	600V
C177	0.005 μ F	Tubular Ceramic	10%	750V
C178	200pF	Polystyrene	5%	125V
C179	20pF	Tubular Ceramic N750	10%	750V
C180	0.1 μ F	Plate Ceramic	+80% -20%	200V
C181	0.01 μ F	Metallised Paper	20%	150V
C182	0.1 μ F	Plate Ceramic	+80% -20%	200V
C183	0.1 μ F	Plate Ceramic	+80% -20%	200V
C184	1500pF	Tubular Ceramic Feed Through	20%	500V
C185	1500pF	Tubular Ceramic Feed Through	20%	500V
C186	0.1 μ F	Plate Ceramic	+80% -20%	200V
C187	0.1 μ F	Plate Ceramic	+80% -20%	200V
C188	0.01 μ F	Metallised Paper	20%	150V
C189	0.01 μ F	Metallised Paper	20%	150V
C190	0.1 μ F	Plate Ceramic	+80% -20%	200V
C191	0.1 μ F	Plate Ceramic	+80% -20%	200V
C192	32 + 32 μ F	Tubular Electrolytic	+50% -20%	350V
C193	25 μ F	Tubular Electrolytic	+100% -20%	25V
C194	50 μ F	Tubular Electrolytic	+50% -20%	450V

Resistors.

Ref	Value	Tol.	Rating	Ref	Value	Tol.	Rating
R1	1M Ω	10%	$\frac{1}{2}$ watt	R20	2,200 Ω	10%	$\frac{1}{2}$ watt
R1a	0.27M Ω	10%	$\frac{1}{2}$ watt	R21	0.47M Ω	10%	$\frac{1}{2}$ watt
R2	12 Ω	10%	$\frac{1}{2}$ watt	R22	1,000 Ω	10%	$\frac{1}{2}$ watt
R3	120 Ω	10%	$\frac{1}{2}$ watt	R23	2.2M Ω	10%	$\frac{1}{2}$ watt
R4	47,000 Ω	10%	$\frac{1}{2}$ watt	R24	10,000 Ω	10%	1 watt
R5	47,000 Ω	10%	1 watt	R25	0.47M Ω	10%	$\frac{1}{2}$ watt
R6	4,700 Ω	10%	1 watt	R26	330 Ω	10%	$\frac{1}{2}$ watt
R7	0.1M Ω	10%	$\frac{1}{2}$ watt	R27	47,000 Ω	10%	1 watt
R8	0.1M Ω	10%	$\frac{1}{2}$ watt	R28	0.27M Ω	10%	$\frac{1}{2}$ watt
R9	560 Ω	10%	$\frac{1}{2}$ watt	R29	100 Ω	10%	$\frac{1}{2}$ watt
R10	680 Ω	10%	$\frac{1}{2}$ watt	R30	47,000 Ω	10%	1 watt
R11	220 Ω	10%	$\frac{1}{2}$ watt	R31	47,000 Ω	10%	1 watt
R12	470 Ω	10%	$\frac{1}{2}$ watt	R32	2,200 Ω	10%	$\frac{1}{2}$ watt
R13	0.47M Ω	10%	$\frac{1}{2}$ watt	R33	10,000 Ω	10%	1 watt
R14	330 Ω	10%	$\frac{1}{2}$ watt	R34	27,000 Ω	10%	1 watt
R15	0.47M Ω	10%	$\frac{1}{2}$ watt	R35	22,000 Ω	10%	1 watt
R16	10,000 Ω	10%	1 watt	R36	27,000 Ω	10%	1 watt
R17	47,000 Ω	10%	1 watt	R37	2,200 Ω	10%	$\frac{1}{2}$ watt
R17a	0.27M Ω	10%	$\frac{1}{2}$ watt	R38	0.27M Ω	10%	$\frac{1}{2}$ watt
R18	22,000 Ω	10%	$\frac{1}{2}$ watt	R39	100 Ω	10%	$\frac{1}{2}$ watt
R19	10,000 Ω	10%	$\frac{1}{2}$ watt				

Ref	Value	Tol.	Rating
R40	1M Ω	10%	1/2 watt
R41	2.2M Ω	10%	1/2 watt
R42	0.1M Ω	10%	1/2 watt
R43	0.1M Ω	10%	1/2 watt
R44	1M Ω	10%	1/2 watt
R45	0.47M Ω	10%	1/2 watt
R46	220 Ω	10%	1/2 watt
R47	4,700 Ω	10%	1 watt
R48	0.27M Ω	10%	1/2 watt
R49	3,300 Ω	10%	1/2 watt
R50	0.18M Ω	10%	1/2 watt
R51	4,700 Ω	10%	1 watt
R52	6,800 Ω	10%	1/2 watt
R53	3,300 Ω	10%	1/2 watt
R54	0.27M Ω	10%	1/2 watt
R55	1M Ω	10%	1/2 watt
R56	0.47M Ω	10%	1/2 watt
R57	47 Ω	10%	1/2 watt
R57a	27,000 Ω	10%	1 watt
R58	330 Ω	10%	1/2 watt
R59	2,200 Ω	10%	1/2 watt
R60	0.1M Ω	10%	1/2 watt
R61	10,000 Ω	10%	1/2 watt
R62	22,000 Ω	10%	1/2 watt
R63	0.27M Ω	10%	1/2 watt
R64	1M Ω	10%	1/2 watt
R65	2.2M Ω	10%	1/2 watt
R65a	0.1M Ω	10%	1/2 watt
R66	47,000 Ω	10%	1 watt
R67	6,800 Ω	10%	1 watt
R68	1,000 Ω	10%	1 watt
R69	2,200 Ω	10%	1 watt

Ref	Value	Tol.	Rating
R70	220 Ω	10%	1/2 watt
R71	2,200 Ω	10%	1/2 watt
R72	6,800 Ω	10%	1/2 watt
R73	47,000 Ω	10%	1/2 watt
R74	47,000 Ω	10%	1/2 watt
R75	220 Ω	10%	1/2 watt
R76	2.2M Ω	10%	1/2 watt
R77	47,000 Ω	10%	1 watt
R78	0.47M Ω	10%	1/2 watt
R79	47 Ω	10%	1/2 watt
R80	47,000 Ω	10%	1/2 watt
R81	470 Ω	10%	1/2 watt
R82	33,000 Ω	10%	1/2 watt
R83	1,000 Ω	10%	1/2 watt
R84	10,000 Ω	10%	1/2 watt
R85	47,000 Ω	10%	1/2 watt
R86	4,700 Ω	10%	1/2 watt
R87	0.1M Ω	10%	1/2 watt
R88	3,300 Ω	10%	1/2 watt
R89	22,000 Ω	10%	1 watt
R90	47,000 Ω	10%	1 watt
R91	47,000 Ω	10%	1 watt
R92	4,700 Ω	10%	1/2 watt
R93	3,300 Ω	10%	1/2 watt
R94	2.2M Ω	10%	1/2 watt
R95	3,300 Ω w.w.	5%	6 watt
R96	3,300 Ω w.w.	5%	6 watt
R97	0.27M Ω	10%	1/2 watt
R98	6,800 Ω	10%	1/2 watt
R99	10,000 Ω	10%	1 watt
R100	140 Ω w.w.	5%	6 watt
R101	140 Ω w.w.	5%	6 watt

Potentiometers.

Ref	Value	Type
RV1*	10,000 Ω	Wirewound
RV2*	10,000 Ω	Wirewound
RV3**	5,000 Ω	Wirewound
RV4	0.5M Ω	Carbon

Ref	Value	Type
RV5	20,000 Ω	Carbon
RV6**	5,600 Ω	Carbon
RV7**	5,600 Ω	Carbon

*Concentric.

**Pre-set.

APPENDIX 'D'

SPARES

The following list details all major spares for the Model 830 receiver. Spares should be ordered by quoting the Circuit Ref. (where applicable), the written description given in the list and the Part No. in the right-hand column. The Serial No. of the receiver should be stated in all communications.

All orders should be addressed to:-

Stratton & Co., Ltd., Sales & Service Dept., Alvechurch Rd., Birmingham, 31.

In cases of extreme urgency, ring PR1ory 2231/4, cable 'Stratnoid', Birmingham or use Telex 33708.

Inductors. (See Note at top of page 43.)

L1	Range 1 Aerial coil	D3244
L2	Range 2 Aerial coil	D3248
L3	Range 3 Aerial coil	D3252
L4	Range 4 Aerial coil	D3256
L5	Range 5 Aerial coil	D3260
L6	Range 6 Aerial coil	D3264
L7	Range 1 RF coil	D3245
L8	Range 2 RF coil	D3249
L9	Range 3 RF coil	D3253
L10	Range 4 RF coil	D3257
L11	Range 5 RF coil	D3261
L12	Range 6 RF coil	D3265
L13	Range 7 Aerial coil	D3268
L14	Range 8 Aerial coil	D3271
L15	Range 9 Aerial coil	D3274
L16	Range 1 Mixer coil	D3246
L17	Range 2 Mixer coil	D3250
L18	Range 3 Mixer coil	D3254
L19	Range 4 Mixer coil	D3258
L20	Range 5 Mixer coil	D3262
L21	Range 6 Mixer coil	D3266
L22	Range 7 Mixer coil	D3269
L23	Range 8 Mixer coil	D3272
L24	Range 9 Mixer coil	D3275
L25	Range 1 Oscillator coil	D3247
L26	Range 2 Oscillator coil	D3251 A
L27	Range 3 Oscillator coil	D3255
L28	Range 4 Oscillator coil	D3259
L29	Range 5 Oscillator coil	D3263
L30	Range 6 Oscillator coil	D3267
L31	Range 7 Oscillator coil	D3270
L32	Range 8 Oscillator coil	D3273
L33	Range 9 Oscillator coil	D3276
L34	1st Mixer Anode coil	D3016
L35	2nd Mixer Grid coil	D3017
L36	2nd Oscillator coil	D3018
L37*	Crystal Calibrator coil	D2178
L38*	Beat Oscillator coil	D3003

* Not normally supplied except with appropriate unit.

NOTE All coils are supplied complete with mounting foot, core, trimming, tracking and coupling capacitors as applicable and damping resistors where required.

Chokes and Transformers.

CH1	HT Smoothing Choke	6260P
CH2	Click Suppression Choke	6461P
T1	1st 100 kc/s IF Transformer	D2992A
T2	100 kc/s Crystal Filter Unit (less crystal)	D3002
T3	2nd 100 kc/s IF Transformer	D2993A
T4	3rd 100 kc/s IF Transformer	D2994A
T5	Output Transformer (600Ω CT and 2.5/3Ω)	D3004
T6	Power Transformer	5339P

Crystals.

XL1/2	100 kc/s ± 0.005% Style 'E'	6099P
-------	---------------------------------------	-------

Switches.

S1	Range Switch: Wafers a-e, h and i	4252P
	Wafers f and g	D3097
	Clicker mechanism	6281P
	Extension spindle	5431P
	Coupler	5428P
S2	Crystal Calibrator Switch	6364P
S3	Crystal Filter Switch	6365P
S4	AGC/NL Switch: 2P3W complete	D3082
S5	Mode Switch: 5P4W complete	D3083
S6	Crystal Selector Switch: complete assembly including gearing	D3010
S7	Mains Switch: DPDT Toggle type	4772P

Variable Capacitors and Associated Items.

C1/C30/C59	Peak RF Tuning Gang, 3 x 5-50pF	D3009
C2/C31	Aerial/RF sections of Main Tuning Gang, 2 x 12-230pF	5814/1P
C58/C159	Mixer/Osc sections of Main Tuning Gang, 2 x 12-230pF	5814/1P
C64/C73/C78	Incremental Tuning Gang, 3 x 7-43pF	5769/1P
	Flexible coupler as used for Main Tuning Gang	D1680
	Flexible coupler as used for Peak RF Gang	D2874
		Short Hub
		Long Hub
	Coupler as used for Incremental Tuning Gang	D3084
	Concentric Trimmer, C9 etc. (4-29pF)	6597P

Potentiometers.

RV1/2	2 x 10,000Ω wirewound with concentric spindles	5810P
RV3	5,000Ω wirewound (pre-set)	6123P
RV4	0.5MΩ carbon	4103PB
RV5	20,000Ω carbon	5938P
RV6/7	5,600Ω carbon (pre-set)	6366P

Plugs.

PL1*	Calibrator Supply Plug (B7G type)	6100P
PL2*	External Power Supply Plug (12-way female)	6080P
PL3*	Accessory Supply Plug (12-way female)	6080P
PL4*	Audio Output (etc.) Plug (12-way male)	6705P
-	Aerial Plug with adaptor to suit 1/4" o/d coaxial cable	6369P
-	Mains Plug (830/2 pattern)	D2311/1

* Supplied complete with removable covers.

Sockets.

SKT1	Aerial Input Socket	6370E
SKT2	IF Output Socket (BNC)	6085E
SKT3	Audio Output (etc.) Socket (12-way female)	6706E
SKT4	Calibrator Supply Socket (B7G type)	6086E
SKT5	External Supply Socket (12-way male)	6088E
SKT6	Mains Input Socket (830/2 and 830/3 pattern)	D231C

Drive Assembly.

Main Drive Unit	LP2795/1
Main Tuning control spindle and bearing assembly	6429E
Flywheel	5174E
Incremental Tuning control spindle assembly	D308E

Knobs.

Main Tuning	6250E
Incremental Tuning	6250E
RF Gain (830, 830/1 and 830/2)	5834E
RF Gain (830/3)	3148/
IF Gain	5786E
Peak RF, BFO Pitch and AF Gain	5816E
Selectivity, Mode and AGC/NL (830, 830/2 and 830/3)	5780E
Selectivity, Mode and AGC/NL (830/1)	D3055
Wavechange	D3008

Miscellaneous.

Chromium plated panel handles	5826E
Scale plate	6257E
Cursor assembly	D3087
Glass window	5847E
Carrier level meter	5956/
Finger plate	6256E
Earth terminal	6371E
Cursor adjustor assembly	D3088
Fuseholder (830 and 830/1)	6372E
Fuseholder (830/2 and 830/3)	6103E
Fuses - 2A (830 and 830/1)	6704E
Fuses - 1.5A Thermal Storage Delay Type (830/2 and 830/3)	6471E
Incremental scale (830 and 830/1)	D2996
Incremental scale (830/2 and 830/3)	D2996/
Drive pulleys	5837E
Guide pulleys	6125E
Dial lamps	3131E
Dial lamp holder	6374E
Valve screening can (B7G)	6126E
Valve screening can (B9A)	6127E
Valve retainer (spring type)	5311E
Telephone socket	6090E
Cursor guide rods	5801E
Rear finger plate (830 and 830/1)	D3015/
Rear finger plate (830/2 and 830/3)	D3015
Crystal holder (Style 'D')	6375E
Dial glass retaining strip	6261E
Calibrator Unit (less valve/crystal)	LP280E
CW/SSB Detector Unit (less valve)	LP2797

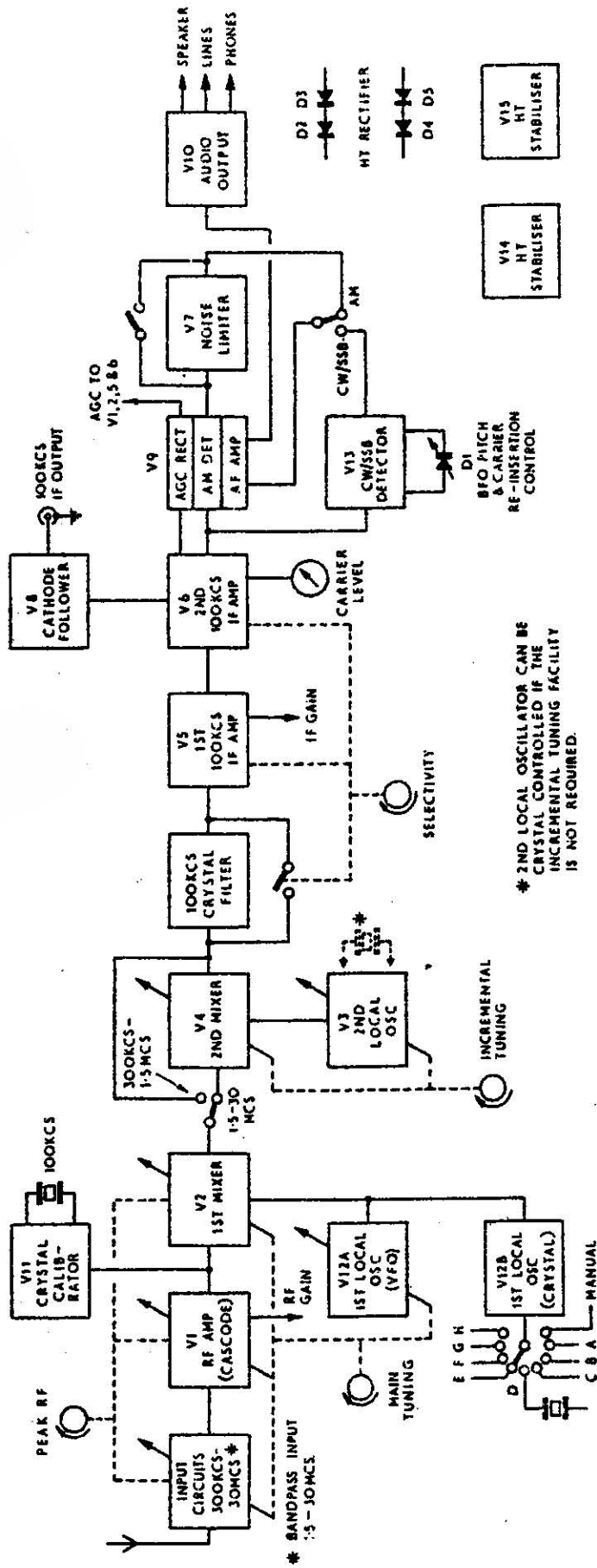

* 2ND LOCAL OSCILLATOR CAN BE CRYSTAL CONTROLLED IF THE INCREMENTAL TUNING FACILITY IS NOT REQUIRED.

Block Schematic Diagram of Model 830.

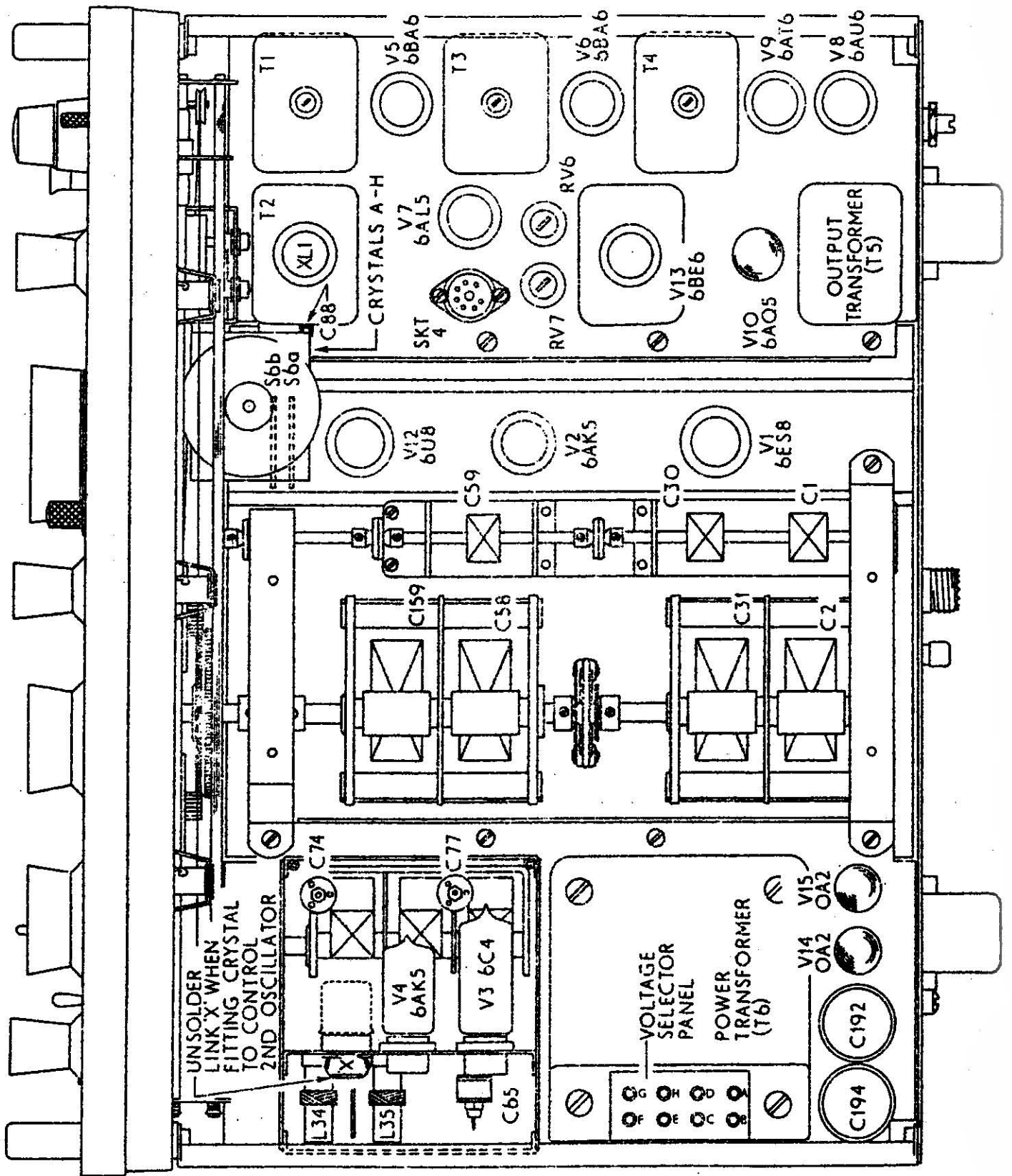

Plan View of Standard 830 Receiver.

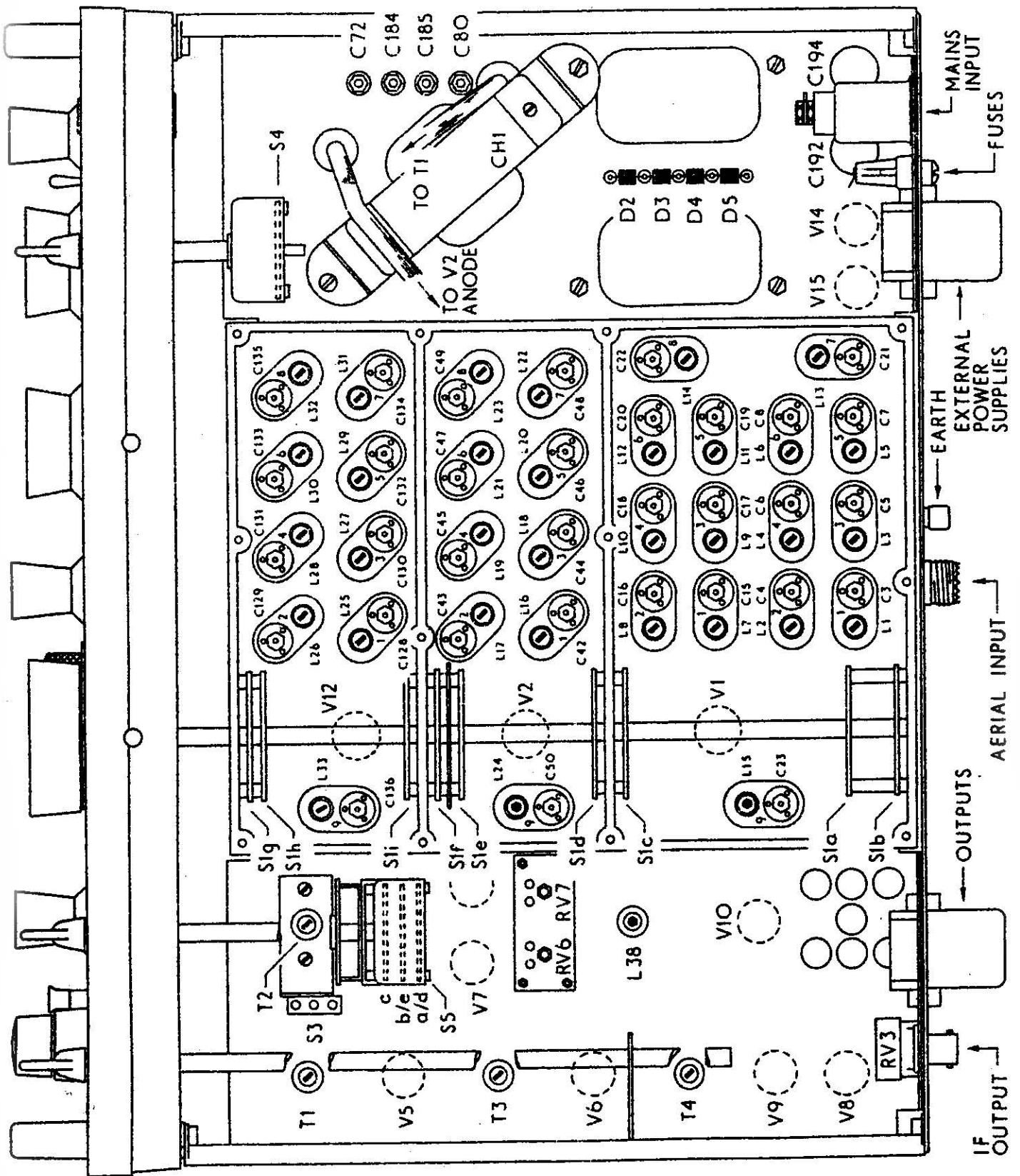

Underside View of Standard 830 Receiver.

Model 830 Series
(Issue 2)

July 1965

AMENDMENT SHEET NO. 1

Circuit Revision. Delete C139 and amend C140 to read "35pF."
Page 39. Delete C139 and amend C140 to read:-
"35pF Tubular Ceramic N750 10% 750V."
Page 42. Amend Part No. for L26 to read "D3251A."



Model 830 Series
(Issue 2)

October 1965

AMENDMENT SHEET NO. 2

Page 37. Add:- "C63a 10pF Tubular Ceramic \pm 10% 750V wkg."
Page 38. Change C75 to read:- "15pF Silvered Mica \pm 10% 350V wkg."
Page 39. Change C140 to read:- "40pF Tubular Ceramic \pm 10% 750V wkg."
Circuit Revisions. (1) Add:- "C63a" (10pF) from cathode of V2 to ground.
(2) Change C75 to read:- "15pF."
(3) Add:- "FB4." This is a small ferrite bead on the earth return from the shorting plate of Sli.



Model 830 Series
(Issue 2)

November 1965

AMENDMENT SHEET NO. 3

Page 37. Change C41 to read:-
"800pF Silvered Mica \pm 10% 350V DC wkg."
Circuit Revision. Change C41 to read:- "800pF."

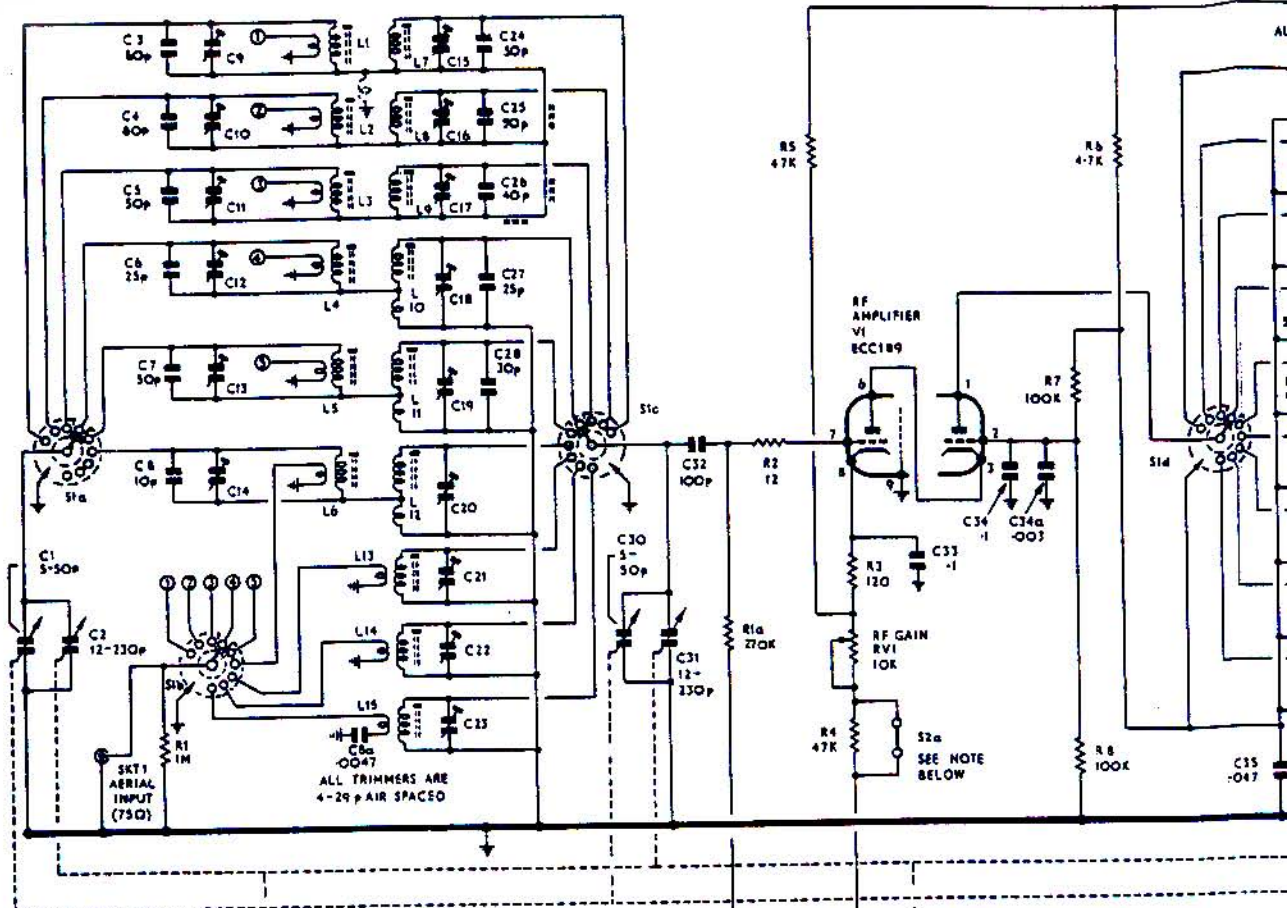

PEAK RF
MAIN TUNING

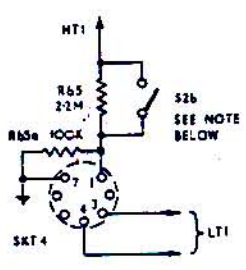
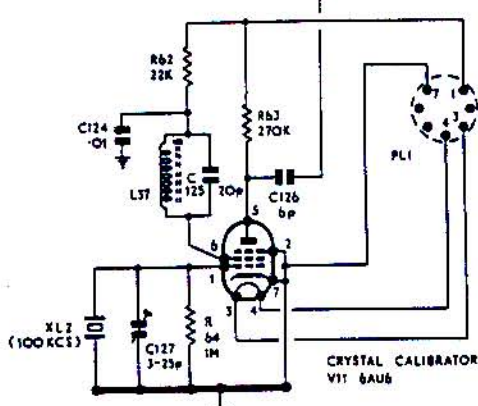

NOTE BOTH SECTIONS OF THE CALIBRATOR SWITCH (S2) ARE SHOWN IN THE 'OFF' POSITION. WHEN SWITCH IS AT 'CALIBRATE' S2a OPENS AND S2b CLOSSES.

MODEL 830.

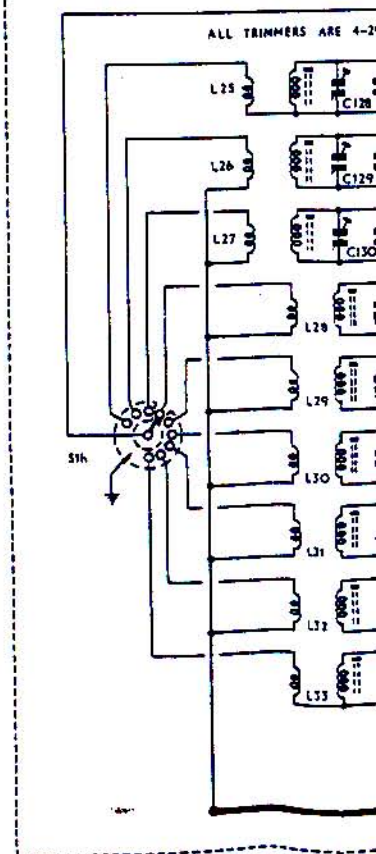

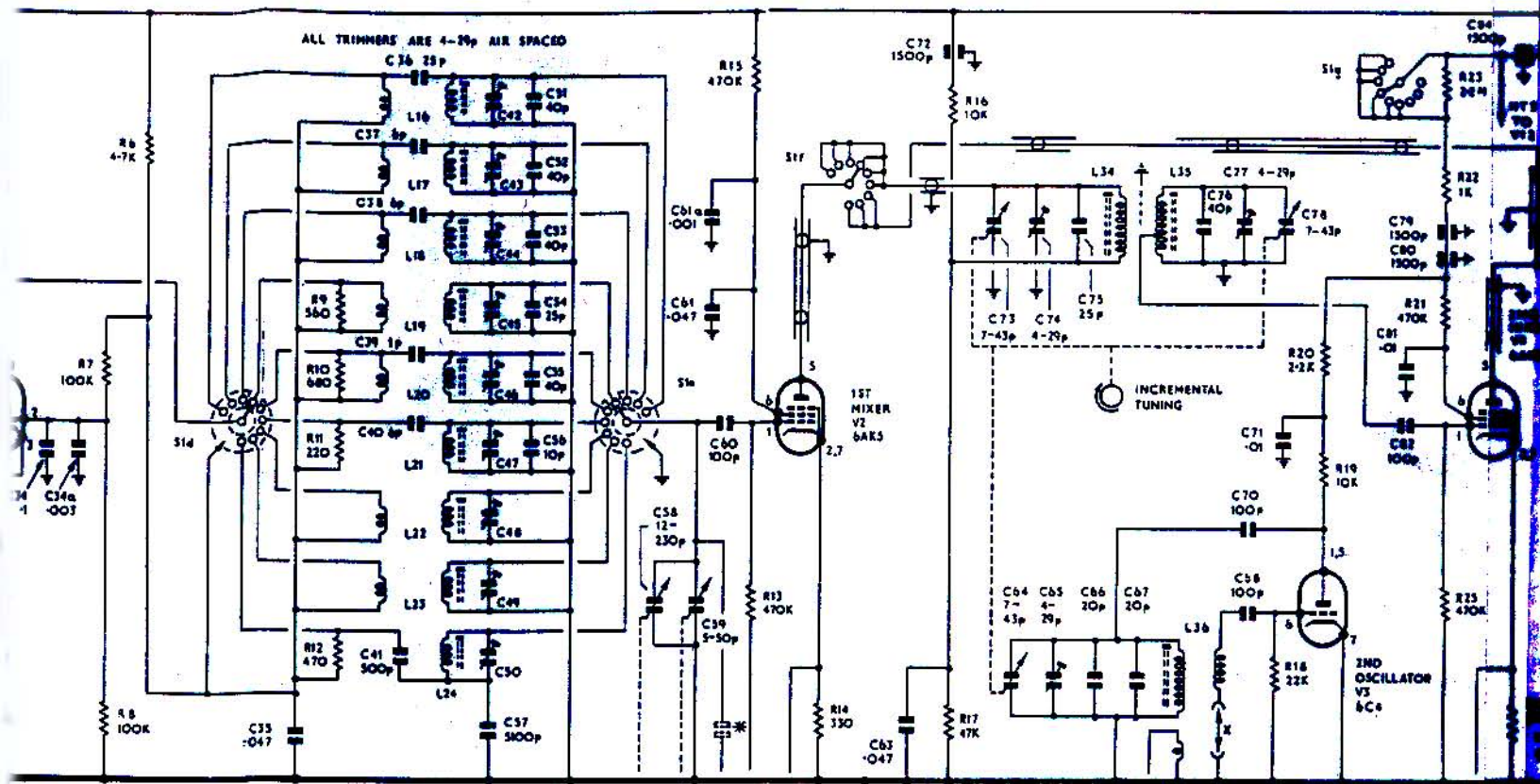

* STRAY CAPACITY COUPLING

ALL SECTIONS OF S1 ARE SHOWN AT RANGE 2

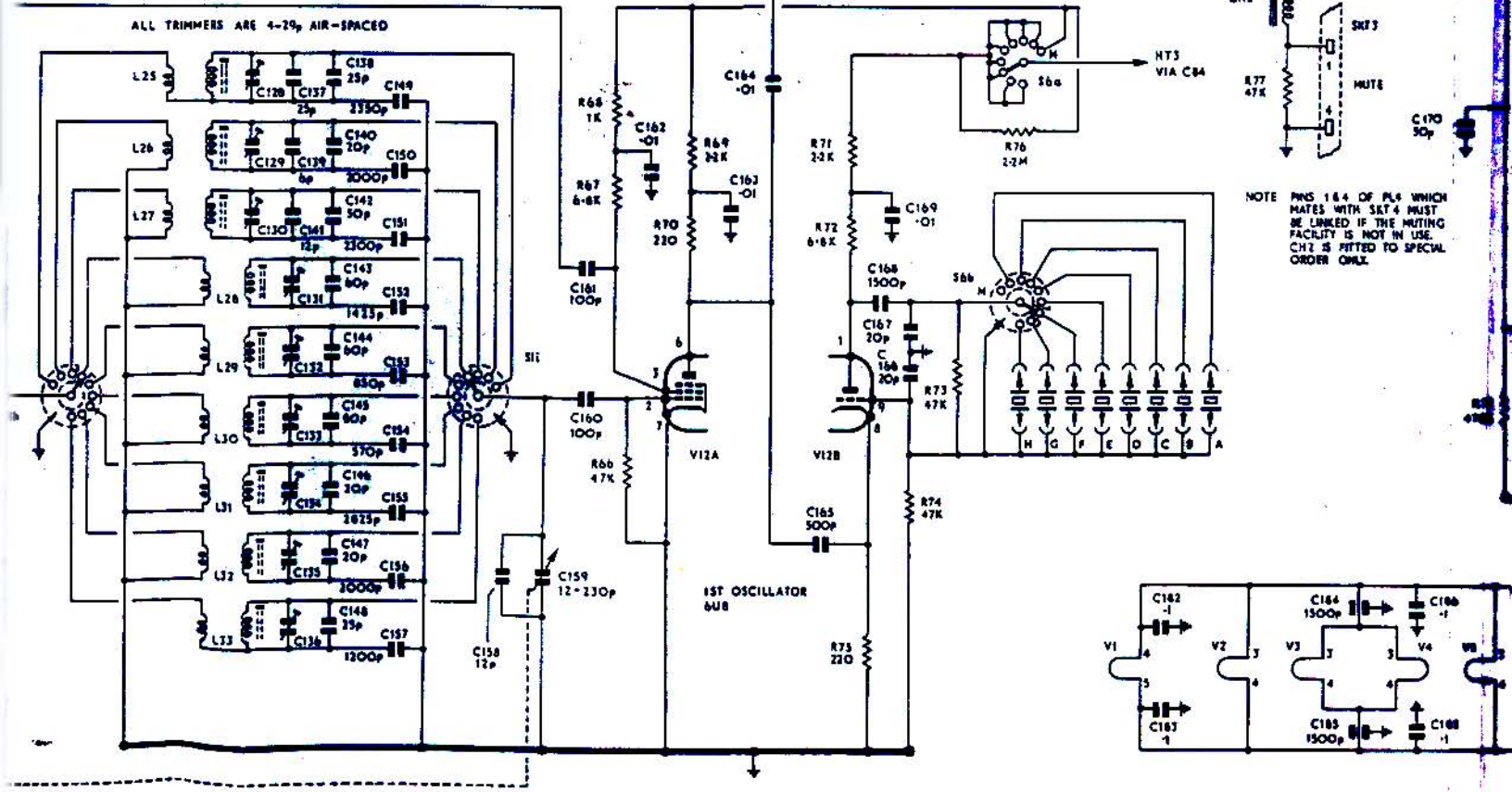

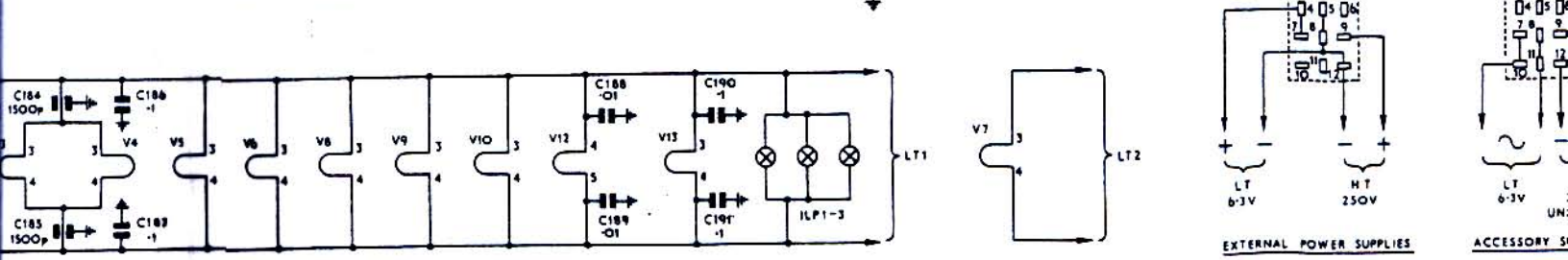
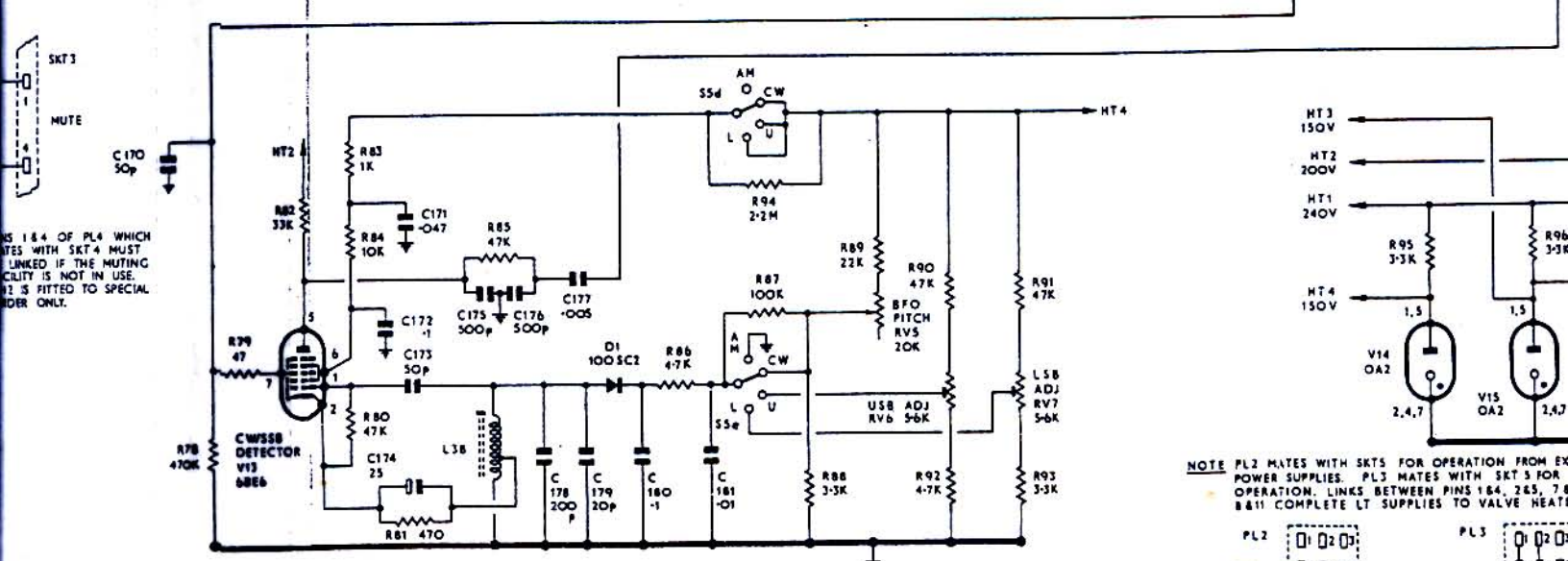
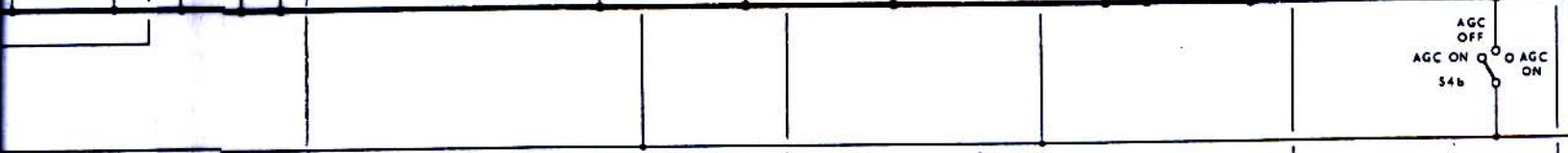
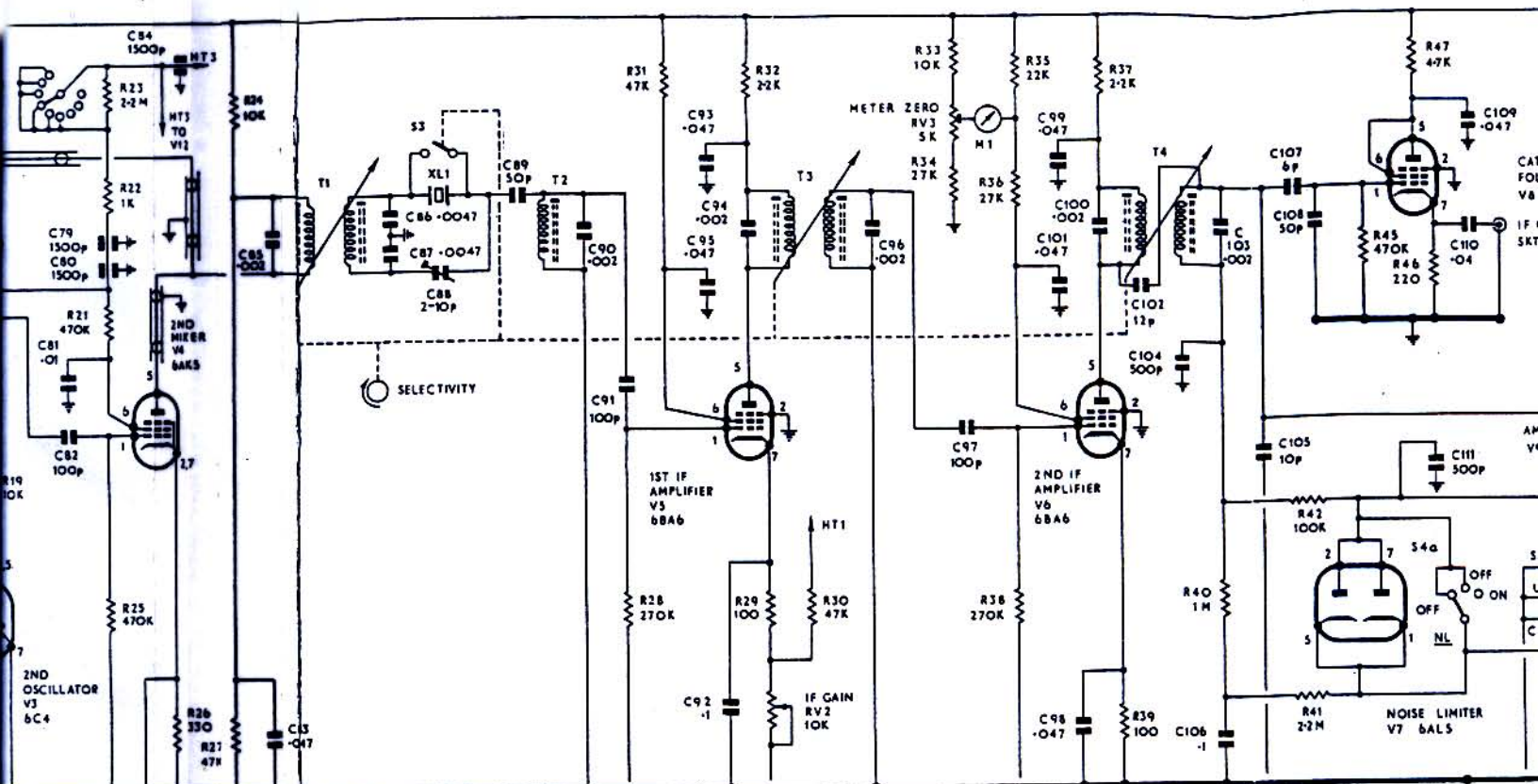

NOTE PL2 MATES WITH SKT3 FOR OPERATION FROM EXTERNAL POWER SUPPLIES. PL3 MATES WITH SKT5 FOR OPERATION. LINKS BETWEEN PINS 1, 8, 2, 6, 5, 7, 8 & 11 COMPLETE LT SUPPLIES TO VALVE HEATS.

EXTERNAL POWER SUPPLIES: LT 6-3V, HT 250V

ACCESSORY SUPPLIES: LT 6-3V

NOTE: MALE CONNECTORS ARE SHOWN THUS: B AND F. CHASSIS MOUNTED CONNECTORS ARE MARKED

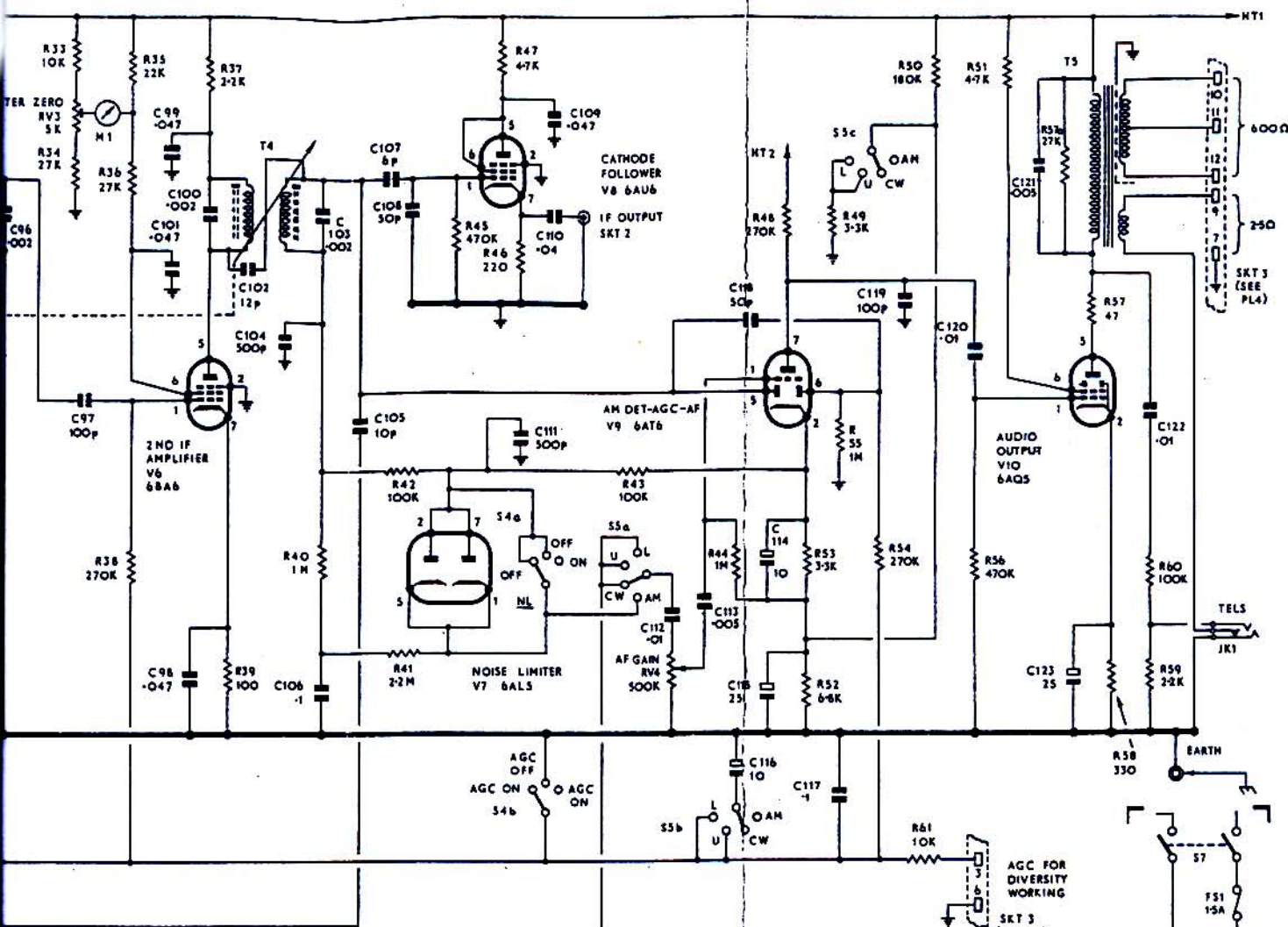

NOTE - T6 PRIMARY TAPS ARE SHOWN SET FOR 200V OPERATION.

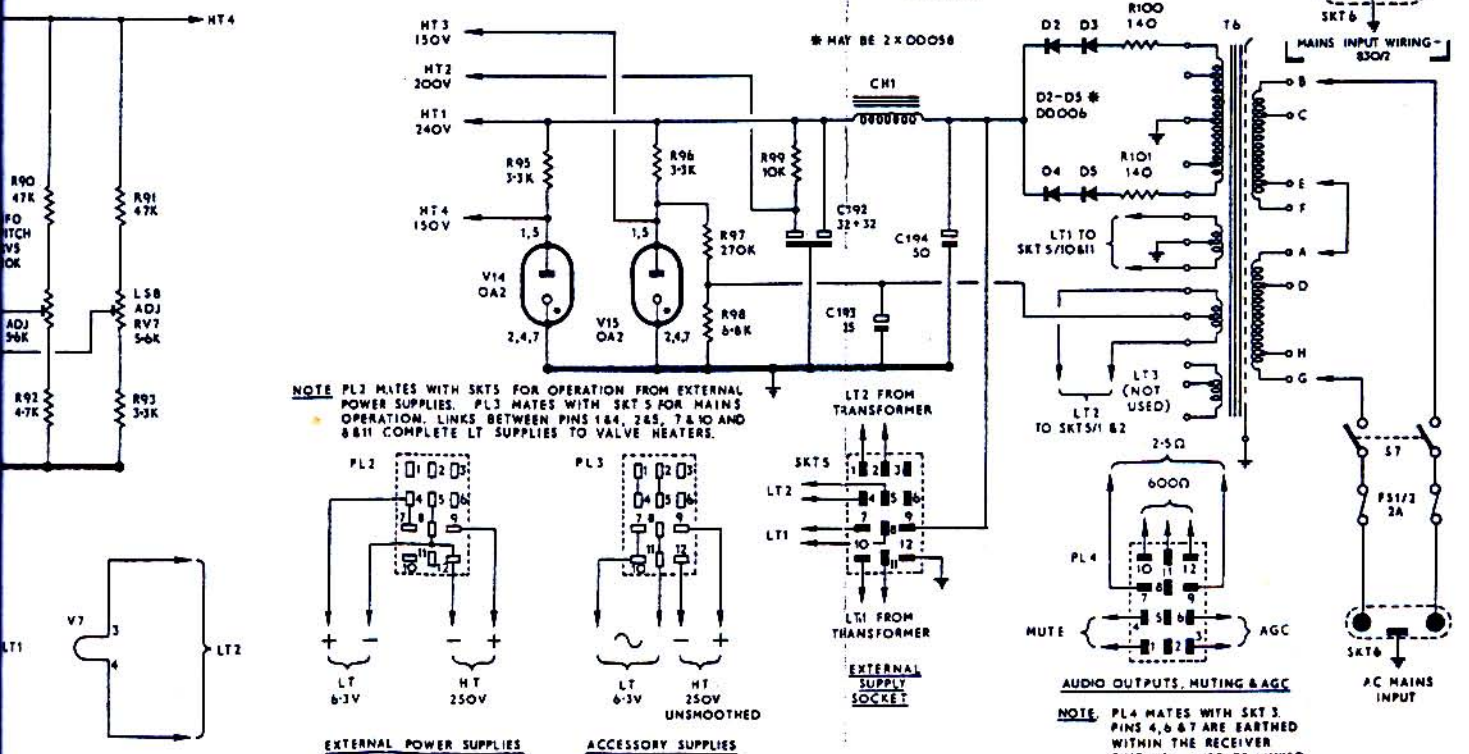

NOTE PL2 MATES WITH SKT5 FOR OPERATION FROM EXTERNAL POWER SUPPLIES. PL3 MATES WITH SKT5 FOR MAINS OPERATION. LINKS BETWEEN PINS 1&4, 2&5, 7&10 AND 8&11 COMPLETE LT SUPPLIES TO VALVE HEATERS.

EXTERNAL POWER SUPPLIES ACCESSORY SUPPLIES

NOTE: MALE CONNECTORS ARE SHOWN THUS: ♂ AND FEMALE ♀ CHASSIS MOUNTED CONNECTORS ARE MARKED 'SKT'

NOTE: PL4 MATES WITH SKT 3. PINS 4, 6 & 7 ARE EARTHED WITHIN THE RECEIVER. PINS 1 & 4 MUST BE LINKED WHEN THE MUTING FACILITY IS NOT IN USE.



© Eddystone Radio Ltd
PRINTED IN ENGLAND